

AXOR

DE / Gebrauchsanleitung / Montageanleitung	02
FR / Mode d'emploi / Instructions de montage	02
EN / Instructions for use / assembly instructions	03
IT / Istruzioni per l'uso / Istruzioni per l'installazione	03
ES / Modo de empleo / Instrucciones de montaje	04
NL / Gebruiksaanwijzing / Handleiding	04
DK / Brugsanvisning / Monteringsvejledning	05
PT / Instruções para uso / Manual de Instalação	05
PL / Instrukcja obsługi / Instrukcja montażu	06
CS / Návod k použití / Montážní návod	06
SK / Návod na použitie / Montážny návod	07
ZH / 用户手册 / 组装说明	07
RU / Руководство пользователя / Инструкция по монтажу	08
FI / Käyttöohje / Asennusohje	08
SV / Bruksanvisning / Monteringsanvisning	09
LT / Vartotojo instrukcija / Montavimo instrukcijos	09
HR / Upute za uporabu / Uputstva za instalaciju	10
TR / Kullanım kılavuzu / Montaj kılavuzu	10
RO / Manual de utilizare / Instrucțiuni de montare	11
EL / Οδηγίες χρήσης / Οδηγία συναρμολόγησης	11
SL / Navodilo za uporabo / Navodila za montažo	12
ET / Kasutusjuhend / Paigaldusjuhend	12
LV / Lietošanas pamācība / Montāžas instrukcija	13
SR / Uputstvo za upotrebu / Uputstvo za montažu	13
NO / Bruksanvisning / Montasjeveiledning	14
BG / Инструкции за употреба / Ръководство за монтаж	14
SQ / Udhëzuesi i përdorimit / Udhëzime rreth montimit	15
AR / دليل الاستخدام / تعليمات التجميع	15
HU / Használati útmutató / Szerelési útmutató	16

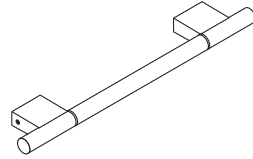

AXOR Uno
41560XXX / 41580XXX

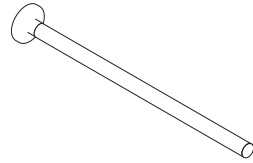

AXOR Uno
41520XXX



AXOR Uno
41538XXX

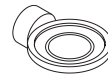

AXOR Uno
41533XXX

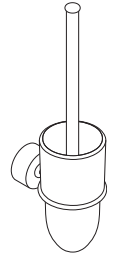

AXOR Uno
41535XXX



AXOR Uno
41521XXX

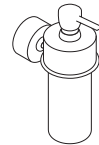

AXOR Uno
41519XXX

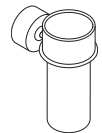

AXOR Uno
41534XXX

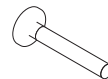

AXOR Uno
41528XXX

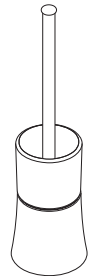

AXOR Uno
41536XXX

△ SICHERHEITSHINWEISE

- △ Bei der Montage müssen zur Vermeidung von Quetsch- und Schnittverletzungen Handschuhe getragen werden.
- △ Es darf ausschließlich nur der Haltegriff 41530XXX zum Festhalten benutzt werden, die übrigen Produkte sind für diesen Einsatzzweck nicht geeignet.
- △ Die ordnungsgemäße Befestigung und der feste Sitz der montierten Produkte ist in periodischen Abständen (jährlich) zu überprüfen.

MONTAGEHINWEISE

- / Bei der Montage des Produktes durch qualifiziertes Fachpersonal ist darauf zu achten, dass die Befestigungsfläche im gesamten Bereich der Befestigung plan ist (keine vorstehenden Fugen oder Fliesenversatz), der Wandaufbau für eine Montage des Produktes geeignet ist und keine Schwachstellen aufweist.
- / Das Glas enthält Bleioxid.

SYMBOLERKLÄRUNG

 Kein essigsäurehaltiges Silikon verwenden!

 MASSE (siehe Seite 17)

 SERVICE TEILE (siehe Seite 22)

XXX = Farbcodierung

000 = Chrom

020 = Polished Chrome

130 = Polished Bronze

140 = Brushed Bronze

250 = Brushed Gold-Optic

260 = Brushed Chrome

300 = Polished Redgold

310 = Brushed Redgold

330 = Polished Black Chrome

340 = Brushed Black Chrome

800 = Stainless Steel Optic

820 = Brushed Nickel

830 = Polished Nickel

930 = Polished Brass

950 = Brushed Brass

990 = Polished Gold-Optic

 REINIGUNG (siehe Seite 20)

Zum Füllen und Reinigen Pumpe und Deckel abnehmen.

 DEMONTAGE (siehe Seite 21)

MONTAGE (siehe Seite 18) 

△ CONSIGNES DE SÉCURITÉ

- △ Lors du montage, porter des gants de protection pour éviter toute blessure par écrasement ou coupure.
- △ N'utiliser que la poignée 41530XXX pour se retenir, les autres produits ne convenant pas à cette utilisation.
- △ Vérifier à intervalles réguliers (une fois par an) la fixation correcte et la bonne assise des produits montés

INSTRUCTIONS POUR LE MONTAGE

- / Lors du montage de ce produit par du personnel qualifié, veiller à ce que la surface de fixation soit bien plane dans toute la zone de fixation (pas de dépassement de joints ou de déport de carreaux), à ce que le mur se prête au montage du produit et ne présente aucun point fragile.
- / Le verre contient de l'oxyde de plomb.

DESCRIPTION DU SYMBOLE

 Ne pas utiliser de silicone contenant de l'acide acétique!

 DIMENSIONS (voir pages 17)

 PIÈCES DÉTACHÉES (voir pages 22)

XXX = Couleurs

000 = Chromé

020 = Polished Chrome

130 = Polished Bronze

140 = Brushed Bronze

250 = Brushed Gold-Optic

260 = Brushed Chrome

300 = Polished Redgold

310 = Brushed Redgold

330 = Polished Black Chrome

340 = Brushed Black Chrome

800 = Stainless Steel Optic

820 = Brushed Nickel

830 = Polished Nickel

930 = Polished Brass

950 = Brushed Brass

990 = Polished Gold-Optic

 NETTOYAGE (voir pages 20)

Retirer la pompe et le couvercle pour remplir et nettoyer.

 DÉMONTAGE (voir pages 21)

MONTAGE (voir pages 18) 

△ SAFETY NOTES

- △ Gloves should be worn during installation to prevent crushing and cutting injuries.
- △ Use only the handle 41530XXX for support, the remaining products are not intended to be used as supports.
- △ Check the proper attachment and tight seating of the installed products periodically (annually).

INSTALLATION INSTRUCTIONS

- / During installation of the product by qualified trained personnel, make sure that the entire fastening surface is even and smooth (no protruding seams or tile offset), that the finish of the wall is suitable to apply the product and has no weak points.
- / The glass contains lead oxide.

SYMBOL DESCRIPTION



Do not use silicone containing acetic acid!



DIMENSIONS (see page 17)



SPARE PARTS (see page 22)

XXX = Colors
 000 = Chrome Plated
 020 = Polished Chrome
 130 = Polished Bronze
 140 = Brushed Bronze
 250 = Brushed Gold-Optic
 260 = Brushed Chrome
 300 = Polished Redgold
 310 = Brushed Redgold
 330 = Polished Black Chrome
 340 = Brushed Black Chrome
 800 = Stainless Steel Optic
 820 = Brushed Nickel
 830 = Polished Nickel
 930 = Polished Brass
 950 = Brushed Brass
 990 = Polished Gold-Optic



CLEANING (see page 20)

Lift off pump and lid for filling and cleaning.



DISMOUNTING (see page 21)

△ INDICAZIONI SULLA SICUREZZA

- △ Durante il montaggio, per evitare ferite da schiacciamento e da taglio bisogna indossare guanti protettivi.
- △ Per tenersi deve essere utilizzato esclusivamente l'impugnatura 41530XXX, gli altri prodotti non sono adatti per questo scopo d'impiego.
- △ Il fissaggio a regola d'arte e la sede fissa dei prodotti montati va controllato a intervallo periodico (annualmente).

ISTRUZIONI PER IL MONTAGGIO

- / Per il montaggio del prodotto da personale specializzato qualificato bisogna fare attenzione, che la superficie di fissaggio, in tutto il campo di fissaggio, sia piana (nessuna giunzione sporgente o sfalsamento di piastrella), la costruzione della parete sia adatta al montaggio del prodotto e che non presenti alcun punto debole.
- / Il vetro contiene ossido di piombo.

DESCRIZIONE SIMBOLO



Non utilizzare silicone contenente acido acetico!



INGOMBRI (vedi pagg. 17)



PARTI DI RICAMBIO
(vedi pagg. 22)

XXX = Trattamento
 000 = Cromato
 020 = Polished Chrome
 130 = Polished Bronze
 140 = Brushed Bronze
 250 = Brushed Gold-Optic
 260 = Brushed Chrome
 300 = Polished Redgold
 310 = Brushed Redgold
 330 = Polished Black Chrome
 340 = Brushed Black Chrome
 800 = Stainless Steel Optic
 820 = Brushed Nickel
 830 = Polished Nickel
 930 = Polished Brass
 950 = Brushed Brass
 990 = Polished Gold-Optic



PULITURA (vedi pagg. 20)

Per riempire e pulire il contenitore togliere la pompa e il coperchio.



SMONTAGGIO (vedi pagg. 21)

ASSEMBLY (see page 18)



MONTAGGIO (vedi pagg. 18)



△ INDICACIONES DE SEGURIDAD

- △ Durante el montaje deben utilizarse guantes para evitar heridas por aplastamiento o corte.
- △ Solo debe utilizarse exclusivamente la manilla 41530XXX para sujetarse, los demás productos no son adecuados para este uso.
- △ Debe comprobarse en intervalos periódicos (anualmente) que los productos montados estén bien fijados y asentados.

INDICACIONES PARA EL MONTAJE

- / Durante el montaje del producto, mediante personal especializado, se debe asegurar de que la superficie de sujeción en todo el área de la fijación sea plana (sin fugas o azulejos que sobresalgan), que la estructura del muro sea adecuada para el montaje del producto y que no presente puntos débiles.
- / El vidrio contiene óxido de plomo.

DESCRIPCIÓN DE SÍMBOLOS

No utilizar silicona que contiene ácido acético!



DIMENSIONES (ver página 17)



REPUESTOS (ver página 22)

XXX = Acabados
 000 = Cromado
 020 = Polished Chrome
 130 = Polished Bronze
 140 = Brushed Bronze
 250 = Brushed Gold-Optic
 260 = Brushed Chrome
 300 = Polished Redgold
 310 = Brushed Redgold
 330 = Polished Black Chrome
 340 = Brushed Black Chrome
 800 = Stainless Steel Optic
 820 = Brushed Nickel
 830 = Polished Nickel
 930 = Polished Brass
 950 = Brushed Brass
 990 = Polished Gold-Optic



LIMPIAR (ver página 20)

Para llenar y limpiar quitar la bomba y la cobertera.



DESPIECE (ver página 21)

NL**△ VEILIGHEIDSINSTRUCTIES**

- △ Bij de montage moeten ter voorkoming van knel- en snijwonden handschoenen worden gedragen.
- △ Alleen de handgreep 41530XXX mag gebruikt worden om zich vast te houden, de overige producten zijn voor dat gebruikdoeleinde niet geschikt.
- △ De reglementaire bevestiging en de vaste zitting van de gemonteerde producten moet regelmatig (jaarlijks) gecontroleerd worden.

MONTAGE-INSTRUCTIES

- / Bij de montage van het product door gekwalificeerd vakpersoneel moet erop gelet worden dat het montagevlak in het volledige bereik van de bevestiging vlak is (geen uitstekende voegen of verspringende tegels), dat de wand geschikt is voor de montage van het product en geen zwakke plaatsen vertoont.
- / Het glas bevat loodoxyde.

SYMBOOLBESCHRIJVING

Gebruik geen zuurhoudende siliconen!



MATEN (zie blz. 17)



SERVICE ONDERDELEN (zie blz. 22)

XXX = Kleuren
 000 = Verchroomd
 020 = Polished Chrome
 130 = Polished Bronze
 140 = Brushed Bronze
 250 = Brushed Gold-Optic
 260 = Brushed Chrome
 300 = Polished Redgold
 310 = Brushed Redgold
 330 = Polished Black Chrome
 340 = Brushed Black Chrome
 800 = Stainless Steel Optic
 820 = Brushed Nickel
 830 = Polished Nickel
 930 = Polished Brass
 950 = Brushed Brass
 990 = Polished Gold-Optic



REINIGEN (zie blz. 20)

Voor het vullen en reinigen pompje en afdekrozet verwijderen.



DEMONTAGE (zie blz. 21)

MONTAJE (ver página 18)



MONTAGE (zie blz. 18)



△ SIKKERHEDSANVISNINGER

- △ Ved monteringen skal der bruges handsker for at undgå kvæstelser og snitsår.
- △ Man må udelukkende bruge håndtaget 41530XXX til at holde sig fast med. De øvrige produkter er ikke egnet til dette formål.
- △ Den korrekte montering og position af monterede produkter skal kontrolleres i regelmæssige afstande (årligt).

MONTERINGSANVISNINGER

- / Ved montering af produktet igennem kvalificerede fagfolk skal der holdes øje med, at fastgørelsesoverfladen er plan i alle områder hvor produktet monteres (ingen fremragende fuger eller fliseforskydninger), at væggene er velegnet til monteringen af produktet og ikke har svare områder.
- / Glasset indeholder blyoxid.

SYMBOLBESKRIVELSE

 Der må ikke benyttes eddikesyreholdig silikone!

 MÅLENE (se s. 17)

 RESERVEDELE (se s. 22)

XXX = Overflade
 000 = Krom
 020 = Polished Chrome
 130 = Polished Bronze
 140 = Brushed Bronze
 250 = Brushed Gold-Optic
 260 = Brushed Chrome
 300 = Polished Redgold
 310 = Brushed Redgold
 330 = Polished Black Chrome
 340 = Brushed Black Chrome
 800 = Stainless Steel Optic
 820 = Brushed Nickel
 830 = Polished Nickel
 930 = Polished Brass
 950 = Brushed Brass
 990 = Polished Gold-Optic

 RENGØRING (se s. 20)

Ved påfyldning og rengøring tag da pumpe og låget af.

 AFMONTERE (se s. 21)

MONTERING (se s. 18)



△ AVISOS DE SEGURANÇA

- △ Durante a montagem devem ser utilizadas luvas de protecção, de modo a evitar ferimentos resultantes de entalamentos e de cortes.
- △ Para se segurar ou apoiar só pode 41530XXX utilizar a pega, visto os outros produtos não serem adequados para esse fim.
- △ A fixação e encaixe correctos dos produtos montados devem ser verificados periodicamente (anualmente).

AVISOS DE MONTAGEM

- / Durante a montagem efectuada por técnicos qualificados deve ter-se em atenção que a superfície de fixação seja plana em toda a sua extensão (sem juntas ou ladrilhos salientes), que a estrutura da parede seja adequada para a montagem do produto e que não apresente pontos fracos.
- / O vidro contém óxido de chumbo.

DESCRIÇÃO DO SÍMBOLO

 Não utilizar silicone que contenha ácido acético!

 MEDIDAS (ver página 17)

 PEÇAS DE SUBSTITUIÇÃO (ver página 22)

XXX = Acabamentos
 000 = Cromado
 020 = Polished Chrome
 130 = Polished Bronze
 140 = Brushed Bronze
 250 = Brushed Gold-Optic
 260 = Brushed Chrome
 300 = Polished Redgold
 310 = Brushed Redgold
 330 = Polished Black Chrome
 340 = Brushed Black Chrome
 800 = Stainless Steel Optic
 820 = Brushed Nickel
 830 = Polished Nickel
 930 = Polished Brass
 950 = Brushed Brass
 990 = Polished Gold-Optic

 LIMPEZA (ver página 20)

Retirar a bomba e a cobertura para encher e limpar.

 DESMONTAR (ver página 21)

MONTAGEM (ver página 18)



△ WSKAZÓWKI BEZPIECZEŃSTWA

- △ Aby uniknąć zranień na skutek zgniecenia lub przecięcia, podczas montażu należy nosić rękawice ochronne.
- △ Do trzymania się może być używany jedynie uchwyt 41530XXX; pozostałe produkty nie nadają się do tego celu.
- △ W określonym czasie (co roku) należy sprawdzać właściwe zamocowanie i odpowiednie osadzenie zamontowanych produktów.

WSKAZÓWKI MONTAŻOWE

- / Montaż produktu musi być wykonany przez wykwalifikowanego fachowca. Powierzchnia w miejscu montażu musi być równa (bez uskoków wzgl. wzajemnie przesuniętych płytek). Ściana w miejscu montażu musi być stabilna. Dołożone w komplecie śruby i kołki rozporowe są przeznaczone do betonu.
- / Szkło zawiera tlenek ołowiu.

OPIS SYMBOLU



Nie stosować silikonów zawierających kwas octowy!



WYMIARY (patrz strona 17)



CZĘŚCI SERWISOWE

(patrz strona 22)

XXX = Kody kolorów

000 = Chrom

020 = Polished Chrome

130 = Polished Bronze

140 = Brushed Bronze

250 = Brushed Gold-Optic

260 = Brushed Chrome

300 = Polished Redgold

310 = Brushed Redgold

330 = Polished Black Chrome

340 = Brushed Black Chrome

800 = Stainless Steel Optic

820 = Brushed Nickel

830 = Polished Nickel

930 = Polished Brass

950 = Brushed Brass

990 = Polished Gold-Optic



CZYSZCZENIE (patrz strona 20)

Do napełniania i czyszczenia pompy zdjąć klapkę.



DEMONTAŻ (patrz strona 21)

MONTAŻ (patrz strona 18)



△ BEZPEČNOSTNÍ POKYNY

- △ Pro zabránění řezným zraněním a pohmožděninám je nutné při montáži nosit rukavice.
- △ K držení se smí používat výlučně držák 41530XXX, ostatní produkty nejsou vhodné pro tento účel použití.
- △ Upevnění podle předpisů a pevné usazení montovaných produktů je třeba kontrolovat v periodických časových intervalech (ročně).

POKYNY K MONTÁŽI

- / Při montáži produktu kvalifikovanou osobou je třeba dbát na to, aby byla upevňovací plocha v celé oblasti upevnění rovná (žádné vyčnívající spáry nebo zapuštění obkladů), aby struktura stěny byla vhodná pro montáž produktu a neměla žádná slabá místa.
- / Sklo obsahuje oxid olovnatý.

POPIS SYMBOLŮ



Nepoužívat silikon s obsahem kyseliny octové!



ROZMĚRY (viz strana 17)



SERVISNÍ DÍLY (viz strana 22)

XXX = Kód povrchové úpravy

000 = Chrom

020 = Polished Chrome

130 = Polished Bronze

140 = Brushed Bronze

250 = Brushed Gold-Optic

260 = Brushed Chrome

300 = Polished Redgold

310 = Brushed Redgold

330 = Polished Black Chrome

340 = Brushed Black Chrome

800 = Stainless Steel Optic

820 = Brushed Nickel

830 = Polished Nickel

930 = Polished Brass

950 = Brushed Brass

990 = Polished Gold-Optic



ČIŠTĚNÍ (viz strana 20)

K naplnění a čištění čerpadla sejmout víko.



DEMONTÁŽ (viz strana 21)

MONTÁŽ (viz strana 18)



△ BEZPEČNOSTNÉ POKYNY

- △ Pri montáži musíte nosiť rukavice, aby ste predišli pomliaždeninám a rezným poraneniam.
- △ Na držanie sa smie používať výlučne držiak 41530XXX, ostatné produkty nie sú vhodné na tento účel použitia.
- △ Upevnenie podľa predpisov a pevné osadenie montovaných produktov treba kontrolovať v periodických časových intervaloch (ročne).

POKYNY PRE MONTÁŽ

- / Pri montáži produktu kvalifikovanou osobou treba dávať pozor na to, aby bola upevňovacia plocha v celej oblasti upevnenia rovná (žiadne vyčnievajúce medzery alebo zapustenia obkladov), aby štruktúra steny bola vhodná pre montáž produktu a nemá žiadne slabé miesta.
- / Sklo obsahuje oxid olovnatý.

POPIS SYMBOLOV

 Nepoužívať silikón s obsahom kyseliny octovej!

 ROZMERY (viď strana 17)

 SERVISNÉ DIELY (viď strana 22)

XXX = Farebné označenie

000 = Chróm

020 = Polished Chrome

130 = Polished Bronze

140 = Brushed Bronze

250 = Brushed Gold-Optic

260 = Brushed Chrome

300 = Polished Redgold

310 = Brushed Redgold

330 = Polished Black Chrome

340 = Brushed Black Chrome

800 = Stainless Steel Optic

820 = Brushed Nickel

830 = Polished Nickel

930 = Polished Brass

950 = Brushed Brass

990 = Polished Gold-Optic

 ČISTENIE (viď strana 20)

Pri plnení a čistení čerpadla odoberte veko.

 DEMONTÁŽ (viď strana 21)

△ 安全技巧

- △ 装配时为避免挤压和切割受伤，必须戴上手套。
- △ 握柄只用于握持41530XXX，其它产品不适用于此项使用用途。
- △ 应定期（每年）检查已装配好的产品是否正常固定和固定定位。

安装提示

- / 由有资格的专业人员进行产品安装时请注意：在所有加固区域中，加固表面是否平整（无突出的接缝或瓷砖），墙体结构是否适合产品安装且未显露出任何缺点。
- / 该玻璃含氧化铅。

符号说明

 请勿使用含有乙酸的硅胶！

 大小 (参见第 17 页)

 备用零件 (参见第 22 页)

XXX = 颜色代码

000 = 镀铬

020 = Polished Chrome

130 = Polished Bronze

140 = Brushed Bronze

250 = Brushed Gold-Optic

260 = Brushed Chrome

300 = Polished Redgold

310 = Brushed Redgold

330 = Polished Black Chrome

340 = Brushed Black Chrome

800 = Stainless Steel Optic

820 = Brushed Nickel

830 = Polished Nickel

930 = Polished Brass

950 = Brushed Brass

990 = Polished Gold-Optic

 清洗 (参见第 20 页)

升高泵和盖子，用于加注和排放。

 拆卸 (参见第 21 页)



△ УКАЗАНИЯ ПО ТЕХНИКЕ БЕЗОПАСНОСТИ

- △ Во время монтажа следует надеть перчатки во избежание прищемления и порезов.
- △ Для фиксации разрешается использовать исключительно рукоятку 41530XXX, остальные изделия непригодны для этой цели.
- △ Надлежащее крепление и плотность посадки установленных изделий следует проверять регулярно (ежегодно).

УКАЗАНИЯ ПО МОНТАЖУ

- / Во время монтажа изделия квалифицированным персоналом поверхность крепления должна быть ровной по всей области крепления (не допускайте выступающих стыков или перекоса облицовочной плитки); для монтажа изделия следует использовать подходящую стену достаточной прочности.
- / Стекло содержит оксид свинца.

ОПИСАНИЕ СИМВОЛОВ



Не применяйте силикон, содержащий уксусную кислоту.



РАЗМЕРЫ (см. стр. 17)



КОМПЛЕКТ (см. стр. 22)

XXX = Цветная кодировка
 000 = Хром
 020 = Polished Chrome
 130 = Polished Bronze
 140 = Brushed Bronze
 250 = Brushed Gold-Optic
 260 = Brushed Chrome
 300 = Polished Redgold
 310 = Brushed Redgold
 330 = Polished Black Chrome
 340 = Brushed Black Chrome
 800 = Stainless Steel Optic
 820 = Brushed Nickel
 830 = Polished Nickel
 930 = Polished Brass
 950 = Brushed Brass
 990 = Polished Gold-Optic



ОЧИСТКА (см. стр. 20)

Для наполнения и очистки снимите насос и крышку.



ДЕМОНТАЖ (см. стр. 21)

МОНТАЖ (см. стр. 18)



△ TURVALLISUUSOHJEET

- △ Asennuksessa on käytettävä käsiineitä puristumien ja viiltojen aiheuttamien tapaturmien estämiseksi.
- △ Vain kahvaa saa käyttää kiinnittämiseen 41530XXX, muut tuotteet eivät sovi käytettäväksi siihen tarkoitukseen.
- △ Asennettujen tuotteiden asianmukainen kiinnitys ja tiukkuus on tarkastettava säännöllisin väliajoin (vuosittain).

ASENNUSOHJEET

- / Pätevän ammattihenkilöstön asentaessa tuotetta on otettava huomioon, että kiinnityspinnan on oltava koko kiinnitysalueelta tasainen (ei korkeita saumoja tai laattojen yhtymäkohtia), seinän rakenne soveltuu tuotteen asennukseen eikä siinä ole heikkoja kohtia.
- / Lasi sisältää lyijyoksidia.

MERKIN KUVAUS



Älä käytä etikkahappopitoista silikonia!



MITAT (katso sivu 17)



VARAOSAT (katso sivu 22)

XXX = Värikooodaus
 000 = Kromi
 020 = Polished Chrome
 130 = Polished Bronze
 140 = Brushed Bronze
 250 = Brushed Gold-Optic
 260 = Brushed Chrome
 300 = Polished Redgold
 310 = Brushed Redgold
 330 = Polished Black Chrome
 340 = Brushed Black Chrome
 800 = Stainless Steel Optic
 820 = Brushed Nickel
 830 = Polished Nickel
 930 = Polished Brass
 950 = Brushed Brass
 990 = Polished Gold-Optic



PUHDISTUS (katso sivu 20)

Poista pumppu ja kansi täyttöä ja puhdistusta varten.



IRROTUS (katso sivu 21)

ASENNUS (katso sivu 18)



△ SÄKERHETSANVISNINGAR

- △ Handskar ska bäras under monteringsarbetet så att man kan undvika kläm- och skärskador.
- △ Det är bara handtaget 41530XXX som får användas till att hålla fast sig i. Övriga produkter är inte lämpliga till detta.
- △ Alla monterade produkter ska kontrolleras regelbundet (varje år) så att de sitter fast ordentligt.

MONTERINGSANVISNINGAR

- / När kvalificerad fackpersonal monterar produkten är det viktigt att fästytan är plan över hela fästsättningsområdet (inga fogar som sticker ut eller kakelförskjutning) och att väggstrukturen är lämplig för en montering av produkten och inte har några svaga punkter.
- / Glaset innehåller blyoxid.

SYMBOLFÖRKLARING

 Använd inte silikon som innehåller ättiksyra!

 MÄTTEN (se sidan 17)

 RESERVDELAR (se sidan 22)

XXX = Färgkodning

000 = Krom

020 = Polished Chrome

130 = Polished Bronze

140 = Brushed Bronze

250 = Brushed Gold-Optic

260 = Brushed Chrome

300 = Polished Redgold

310 = Brushed Redgold

330 = Polished Black Chrome

340 = Brushed Black Chrome

800 = Stainless Steel Optic

820 = Brushed Nickel

830 = Polished Nickel

930 = Polished Brass

950 = Brushed Brass

990 = Polished Gold-Optic

 RENGÖRING (se sidan 20)

Tag bort pump och lock för att fylla och rengöra.

 DEMONTERING (se sidan 21)

△ SAUGUMO TECHNIKOS NURODYMAI

△ Apsaugai nuo užspaudimo ir įsijovimo montavimo metu mūvėkite pirštines.

△ Fiksuoti reikia tik su rankena 41530XXX, kiti gaminiai šiam tikslui nepritaikyti.

△ Gaminių pritvirtinimo teisingumą ir patikimumą būtina periodiškai (kasmet) tikrinti.

MONTAVIMO INSTRUKCIJA

/ Atlikdami montavimo darbus, kvalifikuoti darbuotojai turi atkreipti dėmesį, kad pritvirtinimo plokštuma būtų lygi (be išsikišusių siūlių ar perkreiptų plytelių), sienų konstrukcija tiktų gaminiui montuoti ir neturėtų jokių trūkumų.

/ Stiklo Sudėtyje yra švino oksidas.

SIMBOLIO APRAŠYMAS

 Nenaudokite silikono, kurio sudėtyje yra acto rūgšties!

 IŠMATAVIMAI (žr. psl. 17)

 ATSARGINĖS DALYS (žr. psl. 22)

XXX = Spalvos

000 = Chrom

020 = Polished Chrome

130 = Polished Bronze

140 = Brushed Bronze

250 = Brushed Gold-Optic

260 = Brushed Chrome

300 = Polished Redgold

310 = Brushed Redgold

330 = Polished Black Chrome

340 = Brushed Black Chrome

800 = Stainless Steel Optic

820 = Brushed Nickel

830 = Polished Nickel

930 = Polished Brass

950 = Brushed Brass

990 = Polished Gold-Optic

 VALYMAS (žr. psl. 20)

Valymui nuimkite siurblij ir dangtį.

 IŠMONTAVIMAS (žr. psl. 21)



△ SIGURNOSNE UPUTE

- △ Prilikom montaže se radi sprječavanja prignječenja i posjekotina moraju nositi rukavice.
- △ Za držanje se smije koristiti isključivo držak 41530XXX, svi ostali proizvodi su za tu svrhu neprikladni.
- △ U redovitim vremenskim razmacima (jednom godišnje) valja provjeravati propisnu pričvršćenost i stabilnost postavljenih proizvoda.

UPUTE ZA MONTAŽU

- / Kada proizvod montira kvalificirano stručno osoblje treba paziti da čitava površina na koju se učvršćuje bude ravna (bez istaknutih fuga ili krivljenja pločica), da je zidna konstrukcija primjerena montaži proizvoda te da nema slabih mjesta.
- / Staklo ima olovni oksid.

OPIS SIMBOLA



Nemojte koristiti silikon koji sadrži octenu kiselinu!



MJERE (pogledaj stranicu 17)



REZERVNI DJELOVI
(pogledaj stranicu 22)

XXX = Boje
000 = Krom
020 = Polished Chrome
130 = Polished Bronze
140 = Brushed Bronze
250 = Brushed Gold-Optic
260 = Brushed Chrome
300 = Polished Redgold
310 = Brushed Redgold
330 = Polished Black Chrome
340 = Brushed Black Chrome
800 = Stainless Steel Optic
820 = Brushed Nickel
830 = Polished Nickel
930 = Polished Brass
950 = Brushed Brass
990 = Polished Gold-Optic



ČIŠĆENJE (pogledaj stranicu 20)

Kod punjenja i čišćenja crpke skinite poklopac



RASTAVLJANJE (pogledaj stranicu 21)

△ GÜVENLİK UYARILARI

- △ Montaj esnasında ezilme ve kesilme gibi yaralanmaları önlemek için eldiven kullanılmalıdır.
- △ Tutunmak 41530XXX için sadece tutamak kullanılabilir, diğer ürünler bu kullanıma uygun değildir.
- △ Monte edilmiş ürünlerin talimatlara uygun sabitliği ve sıkı durumu düzenli aralıklarla (yıllık) kontrol edilmelidir.

MONTAJ AÇIKLAMALARI

- / Ürünün yetkili uzman personel tarafından montajı yapılırken, sabitleme yüzeyinin sabitleme planının tüm alanında bulunduğu (derz veya fayans kayması olmamalıdır), duvar yapısının ürünün montajı için uygun olduğuna ve zayıf noktaları bulunmadığına dikkat edilmelidir.
- / Cam kurşun oksit içerir.

SİMGE AÇIKLAMASI



Asetik asit içeren silikon kullanmayın!



ÖLÇÜLERİ (bakınız sayfa 17)



YEDEK PARÇALAR (bakınız sayfa 22)

XXX = Renkler
000 = Krom
020 = Polished Chrome
130 = Polished Bronze
140 = Brushed Bronze
250 = Brushed Gold-Optic
260 = Brushed Chrome
300 = Polished Redgold
310 = Brushed Redgold
330 = Polished Black Chrome
340 = Brushed Black Chrome
800 = Stainless Steel Optic
820 = Brushed Nickel
830 = Polished Nickel
930 = Polished Brass
950 = Brushed Brass
990 = Polished Gold-Optic



TEMİZLEME (bakınız sayfa 20)

Doldurmak ve temizlemek için pompayı ve kapağı çıkartın.



SÖKME (bakınız sayfa 21)



Δ INSTRUȚIUNI DE SIGURANȚĂ

- Δ La montare utilizați mănuși pentru evitarea contuziunilor și tăierii mâinilor.
- Δ Utilizați exclusiv mâner de sprijin 41530XXX pentru a vă sprijini, celelalte produse nu sunt potrivite pentru a fi utilizate cu acest scop.
- Δ Fixarea corespunzătoare și poziția fixă a produselor montate trebuie verificate la intervale regulate (anual).

INSTRUCȚIUNI DE MONTARE

- / La montarea produsului de către un personal calificat se va avea grijă ca suprafața de fixare să fie plană pe toată aria de fixare (fără proeminențe ale rosturilor sau îmbinări între plăcile de faianță) și ca structura peretelui să fie corespunzătoare pentru fixarea produsului, să nu prezinte locuri cu rezistență redusă.
- / Sticlă conține oxid de plumb.

DESCRIEREA SIMBOLURILOR

 Nu utilizați silicon cu conținut de acid acetic!

 DIMENSIUNI (vezi pag. 17)

 PIESE DE SCHIMB (vezi pag. 22)

XXX = Coduri de culori
 000 = Crom
 020 = Polished Chrome
 130 = Polished Bronze
 140 = Brushed Bronze
 250 = Brushed Gold-Optic
 260 = Brushed Chrome
 300 = Polished Redgold
 310 = Brushed Redgold
 330 = Polished Black Chrome
 340 = Brushed Black Chrome
 800 = Stainless Steel Optic
 820 = Brushed Nickel
 830 = Polished Nickel
 930 = Polished Brass
 950 = Brushed Brass
 990 = Polished Gold-Optic

 CURĂȚARE (vezi pag. 20)

Pentru umplere și curățare scoateți pompa și capacul.

 DEMONTARE (vezi pag. 21)

Δ ΥΠΟΔΕΙΞΕΙΣ ΑΣΦΑΛΕΙΑΣ

- Δ Για να αποφύγετε τραυματισμούς κατά τη συναρμολόγηση πρέπει να φοράτε γάντια.
- Δ Μπορεί να χρησιμοποιηθεί αποκλειστικά για κράτημα μόνο η λαβή 41530XXX. Τα υπόλοιπα προϊόντα είναι ακατάλληλα για τη χρήση αυτή.
- Δ Θα πρέπει να ελέγχετε ανά διαστήματα (ετησίως) αν η στερέωση εξακολουθεί να είναι επαρκής και αν τα τοποθετημένα προϊόντα σφίγγονται καλά.

ΟΔΗΓΙΕΣ ΣΥΝΑΡΜΟΛΟΓΗΣΗΣ

- / Κατά τη συναρμολόγηση του προϊόντος από ειδικό προσωπικό θα πρέπει να ελέγχεται με ιδιαίτερη προσοχή η επιφάνεια στερέωσης, αν είναι επίπεδη σε όλη της την επιφάνεια (δεν πρέπει να εξέχουν αρμοί ή πλακάκια), αν η υποδομή του τοίχου είναι κατάλληλη για τη στερέωση του προϊόντος και αν παρουσιάζει ασθενή σημεία.
- / Το γυαλί που περιέχει οξείδιο του μολύβδου.

ΠΕΡΙΓΡΑΦΗ ΣΥΜΒΟΛΩΝ

 Μην χρησιμοποιείτε σιλικόνη που περιέχει οξικό οξύ!

 ΔΙΑΣΤΑΣΕΙΣ (βλ. Σελίδα 17)

 ΑΝΤΑΛΛΑΚΤΙΚΑ (βλ. Σελίδα 22)

XXX = Χρώματα
 000 = Επιχρωμωμένο
 020 = Polished Chrome
 130 = Polished Bronze
 140 = Brushed Bronze
 250 = Brushed Gold-Optic
 260 = Brushed Chrome
 300 = Polished Redgold
 310 = Brushed Redgold
 330 = Polished Black Chrome
 340 = Brushed Black Chrome
 800 = Stainless Steel Optic
 820 = Brushed Nickel
 830 = Polished Nickel
 930 = Polished Brass
 950 = Brushed Brass
 990 = Polished Gold-Optic

 ΚΑΘΑΡΙΣΜΟΣ (βλ. Σελίδα 20)

Για την πλήρωση και τον καθαρισμό της αντλίας, να αφαιρέτε το κάλυμμα.

 ΑΠΟΣΥΝΑΡΜΟΛΟΓΗΣΗ (βλ. Σελίδα 21)

ΜΟΝΤΑΡΕ (vezi pag. 18) 

ΣΥΝΑΡΜΟΛΟΓΗΣΗ (βλ. Σελίδα 18) 

△ VARNOSTNA OPOZORILA

- △ Pri montaži je treba nositi rokavice, da se preprečijo poškodbe zaradi zmečkanja ali urezov.
- △ Za držanje se sme uporabljati izključno držalni ročaj 41530XXX, preostali proizvodi niso primerni za tovrstno uporabo.
- △ V periodičnih presledkih (letno) je treba preverjati pravilno pritrđitev in trdnost naseda montiranih proizvodov.

NAVODILA ZA MONTAŽO

- / Pri montaži tega proizvoda s strani kvalificiranega strokovnega osebja je treba paziti na to, da je pritrđilna ploskev na celotni površini za pritrđitev gladka (brez izstopajočih fug ali zasekov ploščic), da je struktura stene primerna za montažo proizvoda in ne kaže šibkih mest.
- / Steklo vsebuje svinčeni oksid.

OPIS SIMBOLA

Ne smete uporabiti silikona, ki vsebuje ocetno kislino!



MERE (glejte stran 17)



REZERVNI DELI (glejte stran 22)

XXX = Barve

000 = Krom

020 = Polished Chrome

130 = Polished Bronze

140 = Brushed Bronze

250 = Brushed Gold-Optic

260 = Brushed Chrome

300 = Polished Redgold

310 = Brushed Redgold

330 = Polished Black Chrome

340 = Brushed Black Chrome

800 = Stainless Steel Optic

820 = Brushed Nickel

830 = Polished Nickel

930 = Polished Brass

950 = Brushed Brass

990 = Polished Gold-Optic



ČIŠČENJE (glejte stran 20)

Pri polnjenju in čiščenju snemite črpalko in pokrov.



DEMONTAŽA (glejte stran 21)

△ OHUTUSJUHISED

- △ Kandke paigaldamisel muljumis- ja lõikevlgastuste vältimiseks kindaid.
- △ Käepidet41530XXX võib kasutada ainult kinnihoidmiseks, ülejäänud tooted ei sobi selleks kasutusotstarbeks.
- △ Monteeritud toote nõuetekohast paigaldust ja kinnitust tuleb korrapäraselt (kord aastas) kontrollida.

PAIGALDAMISJUHISED

- / Toote paigaldamisel kvalifitseeritud spetsialistide poolt tuleb jälgida, et kinnituspind oleks kogu ulatuses ühtlaselt tasane (mitte ühtki üleseisvat vuuki või kaldus kahhelkivi), seina ülesehitus toote paigaldamiseks sobiv ja ilma nõrkade kohtadeta.
- / Klaasi sisaldab pliioksiidi.

SÜMBOLITE KIRJELDUS

Ärge kasutage äädikhapet sisaldavat silikoonil



MÕÕTUDE (vt lk 17)



VARUOSAD (vt lk 22)

XXX = Värvid

000 = Kroom

020 = Polished Chrome

130 = Polished Bronze

140 = Brushed Bronze

250 = Brushed Gold-Optic

260 = Brushed Chrome

300 = Polished Redgold

310 = Brushed Redgold

330 = Polished Black Chrome

340 = Brushed Black Chrome

800 = Stainless Steel Optic

820 = Brushed Nickel

830 = Polished Nickel

930 = Polished Brass

950 = Brushed Brass

990 = Polished Gold-Optic



PUHASTAMINE (vt lk 20)

Eemaldage täitmis ja puhastus pumba kate täitmiseks ja puhastamiseks.



MAHAMONTEERIMINE (vt lk 21)

MONTAŽA (glejte stran 18)



PAIGALDAMINE (vt lk 18)



△ DROŠĪBAS NORĀDES

- △ Montāžas laikā, lai izvairītos no saspiedumiem un iegrīzumiem, nepieciešams nēsāt cimdus.
- △ Turēšanai drīkst izmantot vienīgi rokturi 41530XXX, pārējie produkti nav piemēroti šim nolūkam.
- △ Nepieciešams periodiski (reizi gadā) pārbaudīt, vai uzmontētie produkti ir pareizi piestiprināti un labi turas.

NORĀDĪJUMI MONTĀŽAI

- / Kvalificētiem speciālistiem, montējot produktu, jāpiegriež vērība tam, lai piestiprināšanas virsma visā piestiprināšanas zonā ir gluda (nav fūgu vai flīžu iecirtumu), sienas uzbūve ir piemērota produkta montāžai un tajā nav nestabilu vietu.
- / Stikla satur svina oksīds.

SIMBOLU NOZĪME

 Neizmantot silikonu, kas satur etiķskābi!

 IZMĒRUS (skat. lpp. 17)

 REZERVES DAĻAS (skat. lpp. 22)

XXX = Krāsu kodi

000 = Hroma

020 = Polished Chrome

130 = Polished Bronze

140 = Brushed Bronze

250 = Brushed Gold-Optic

260 = Brushed Chrome

300 = Polished Redgold

310 = Brushed Redgold

330 = Polished Black Chrome

340 = Brushed Black Chrome

800 = Stainless Steel Optic

820 = Brushed Nickel

830 = Polished Nickel

930 = Polished Brass

950 = Brushed Brass

990 = Polished Gold-Optic

 TĪRĪŠANA (skat. lpp. 20)

Lai piepildītu un iztīrītu, noņemiet sūkni un vāciņu.

 DEMONTĀŽA (skat. lpp. 21)

△ SIGURNOSNE NAPOMENE

- △ Prilikom montaže se radi sprečavanja prignječenja i posekotina moraju nositi rukavice.
- △ Za držanje sme da se koristi isključivo drška 41530XXX, svi ostali proizvodi su za tu svrhu nepodesni.
- △ Propisna pričvršćenost i stabilnost postavljenih proizvoda treba redovno da se proverava (jednom godišnje).

INSTRUKCIJE ZA MONTAŽU

- / Kada proizvod montira kvalifikovano stručno osoblje treba paziti da čitava površina na koju se učvršćuje bude ravna (bez istaknutih fuga ili krivljenja pločica), da je zidna konstrukcija primerena montaži proizvoda i da nema slabih mesta.
- / Staklo sadrži olovo oksid.

OPIS SIMBOLA

 Nemojte koristiti silikon koji sadrži sirćetnu kiselinu!

 MERE (vidi stranu 17)

 REZERVNI DELOVI (vidi stranu 22)

XXX = Oznake boja

000 = Hrom

020 = Polished Chrome

130 = Polished Bronze

140 = Brushed Bronze

250 = Brushed Gold-Optic

260 = Brushed Chrome

300 = Polished Redgold

310 = Brushed Redgold

330 = Polished Black Chrome

340 = Brushed Black Chrome

800 = Stainless Steel Optic

820 = Brushed Nickel

830 = Polished Nickel

930 = Polished Brass

950 = Brushed Brass

990 = Polished Gold-Optic

 ČIŠĆENJE (vidi stranu 20)

Kod punjenja i čišćenja pumpe skinite poklopac.

 RASTAVLJANJE (vidi stranu 21)

MONTĀŽA (skat. lpp. 18) 

MONTĀŽA (vidi stranu 18) 

△ SIKKERHETSHENVISNINGER

- △ Bruk hansker under montasjen for å unngå klem- og kuttskader.
- △ For å holde seg fast skal kun håndtaket brukes 41530XXX. De øvrige produktene er ikke egnet for dette bruk.
- △ De monterte produktene skal regelmessig sjekkes om de er ordentlig festet og om de sitter fast.

MONTAGEHENVISNINGER

- / Under monteringen av produktet gjort av kvalifisert fagperson, skal man påse at monteringsoverflaten på hele festeområdet er plant (ingen utstikkende fuger eller flisekanter), at veggoppbyggingen egner seg for produktmontasjen og ikke viser svake punkter.
- / Glasset inneholder blyoksid.

SYMBOLBESKRIVELSE



Ikke bruk silikon som inneholder eddiksyre!



MÅL (se side 17)



SERVICEDELER (se side 22)

XXX = Fargekode

000 = Krom

020 = Polished Chrome

130 = Polished Bronze

140 = Brushed Bronze

250 = Brushed Gold-Optic

260 = Brushed Chrome

300 = Polished Redgold

310 = Brushed Redgold

330 = Polished Black Chrome

340 = Brushed Black Chrome

800 = Stainless Steel Optic

820 = Brushed Nickel

830 = Polished Nickel

930 = Polished Brass

950 = Brushed Brass

990 = Polished Gold-Optic



RENGJØRING (se side 20)

Ta av deksel og pumpe for fylling og rengjøring.



DEMONTASJE (se side 21)

MONTASJE (se side 18)



△ УКАЗАНИЯ ЗА БЕЗОПАСНОСТ

- △ При монтажа трябва да се носят ръкавици, за да се избегнат наранявания поради притискане или порязване.
- △ За хващане да се използва само држката 41530XXX, останалите продукти не са подходящи за тази цел.
- △ Правилното закрепване и правилното разположение на монтираните продукти трябва да се проверява периодично (ежегодно).

УКАЗАНИЯ ЗА МОНТАЖ

- / При монтаж на продукта от квалифицирани специалисти да се внимава за това, закрепващата повърхност в целия диапазон на закрепването да бъде равна (без изпъкнали fugи или изместване на плочки), конструкцията на стената да е подходяща за монтаж на продукта и да няма слаби места.
- / Стъклото съдържа оловен оксид.

ОПИСАНИЕ НА СИМВОЛИТЕ



Не използвайте силикон, съдържащ оцетна киселина!



РАЗМЕРИ (вижте стр. 17)



СЕРВИЗНИ ЧАСТИ (вижте стр. 22)

XXX = Цветово кодиране

000 = Хром

020 = Polished Chrome

130 = Polished Bronze

140 = Brushed Bronze

250 = Brushed Gold-Optic

260 = Brushed Chrome

300 = Polished Redgold

310 = Brushed Redgold

330 = Polished Black Chrome

340 = Brushed Black Chrome

800 = Stainless Steel Optic

820 = Brushed Nickel

830 = Polished Nickel

930 = Polished Brass

950 = Brushed Brass

990 = Polished Gold-Optic



ПОЧИСТВАНЕ (вижте стр. 20)

За пълнене и почистване свалете помпата и капака.



ДЕМОНТАЖ (вижте стр. 21)

МОНТАЖ (вижте стр. 18)



△ UDHËZIME SIGURIE

- △ Për të evituar lëndimet e pickimeve ose të prerjeve gjatë procesit të montimit duhet që të vishni doreza.
- △ Vetëm doreza 41530XXX mund të përdoret për t'u mbajtur. Të gjitha produktet e tjera nuk janë të përshtatshme për këtë qëllim.
- △ Montimi dhe pozicioni sipas rregullave i produkteve të montuara duhet verifikuar periodikisht (një herë në vit).

UDHËZIME PËR MONTIMIN

- / Gjatë montimit të produktit nga teknikët e specializuar duhet mbajtur parasysh që sipërfaqja e montimit gjendet brenda zonës së përgjithshme të planit të montimit (nuk ka vendbashkime të dala ose mospërputhje të pllakave), që struktura e murit është e përshtatshme për montimin e produktit dhe që nuk paraqet asnjë pikë të dobët.
- / Xhami përmban oksid plumbi.

PËRSHKRIMI I SIMBOLIT



Mos përdorni silikon që në përbërje ka acid acetik.



PËR MASAT (shih faqen 17)



PJESËT E SERVISIT (shih faqen 22)

XXX = Kodimi me anë të ngjyrave
 000 = Krom
 020 = Polished Chrome
 130 = Polished Bronze
 140 = Brushed Bronze
 250 = Brushed Gold-Optic
 260 = Brushed Chrome
 300 = Polished Redgold
 310 = Brushed Redgold
 330 = Polished Black Chrome
 340 = Brushed Black Chrome
 800 = Stainless Steel Optic
 820 = Brushed Nickel
 830 = Polished Nickel
 930 = Polished Brass
 950 = Brushed Brass
 990 = Polished Gold-Optic



PASTRIMI (shih faqen 20)

Për mbushje dhe pastrim të hiqen pompa dhe kapaku.



ÇMONTIMI (shih faqen 21)

MONTIMI (shih faqen 18)



△ تنبيهات الأمان

- △ يجب ارتداء قفازات لليد أثناء التركيب لتجنب حدوث أضرار الإنحشار أو الجروح.
- △ يحظر استخدام المقبض إلا من أجل التثبيت فحسب 41530XXX. وبالنسبة لبقية المنتجات الأخرى، فهي غير صالحة لهذا الغرض من الاستخدام.
- △ يتعين التأكد من أن حالة التثبيت مطابقة للشروط المحددة والتأكد من الوضع الثابت للمنتجات المركبة على فترات منتظمة (سنوياً).

تعليمات التركيب

- / عند التركيب بواسطة عمال تركيب متخصصين يجب الانتباه إلى أن مساحة التثبيت في مكان التركيب بوجه عام مسطحة (لا توجد روابط أو فروق للربط بين البلاطات). لذا يجب التأكد من أن الحائط الذي سيتم تركيب المنتج عليه صالح لذلك وأنه لا يوجد به نقاط ضعف.
- / يحتوي الزجاج أكسيد الرصاص.

وصف الرمز

هام! لا تستخدم السليكون الذي يحتوي على أحماض!



أبعاد (راجع صفحة 17)



قطع الغيار (راجع صفحة 22)



XXX = الألوان

000 = كروم

Polished Chrome = 020

Polished Bronze = 130

Brushed Bronze = 140

Brushed Gold-Optic = 250

Brushed Chrome = 260

Polished Redgold = 300

Brushed Redgold = 310

Polished Black Chrome = 330

Brushed Black Chrome = 340

Stainless Steel Optic = 800

Brushed Nickel = 820

Polished Nickel = 830

Polished Brass = 930

Brushed Brass = 950

Polished Gold-Optic = 990

التنظيف (راجع صفحة 20)



ارفع المضخة والغطاء للماء والتنظيف.

فك التركيب (راجع صفحة 21)



التركيب (راجع صفحة 18)

△ BIZTONSÁGI UTASÍTÁSOK

- △ A szerelésnél a zúzódások és vágási sérülések elkerülése érdekében kesztyűt kell viselni.
- △ Kapaszkodáshoz kizárólag csak a kapaszkodót 41530XXX szabad használni, a további termékek nem alkalmasak ilyen jellegű használatra.
- △ A felszerelt termékek szabályszerű rögzítését és szilárd elhelyezkedését rendszeres időközönként (évente) ellenőrizni kell.

SZERELÉSI UTASÍTÁSOK

- / A termék képzett szakember általi felszerelése esetén ügyelni kell arra, hogy a rögzítési felület teljesen sima legyen (ne legyen kiálló fuga vagy csempe), a fal szerkezete a termék felszerelésére alkalmas legyen, és ne legyen gyenge pontja.
- / Az üveg ólom-oxidot tartalmaz.

SZIMBÓLUMOK LEÍRÁSA



Ne használjon ecetsavtartalmú szilikon!



MÉRETET (lásd a oldalon 17)



TARTOZÉKOK (lásd a oldalon 22)

XXX = Színkódolás

000 = Króm

020 = Polished Chrome

130 = Polished Bronze

140 = Brushed Bronze

250 = Brushed Gold-Optic

260 = Brushed Chrome

300 = Polished Redgold

310 = Brushed Redgold

330 = Polished Black Chrome

340 = Brushed Black Chrome

800 = Stainless Steel Optic

820 = Brushed Nickel

830 = Polished Nickel

930 = Polished Brass

950 = Brushed Brass

990 = Polished Gold-Optic



TISZTÍTÁS (lásd a oldalon 20)

A töltéshez és tisztításhoz vegye le a szivattyút és a fedelet.



LESZERELÉS (lásd a oldalon 21)





AXOR Uno
41538XXX

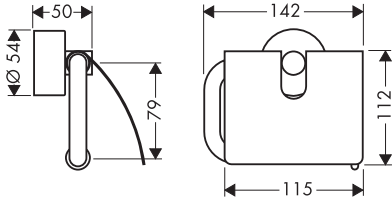

AXOR Uno
41519XXX

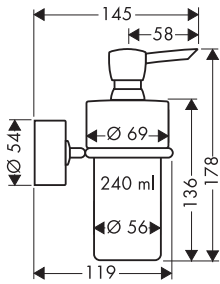

AXOR Uno
41520XXX

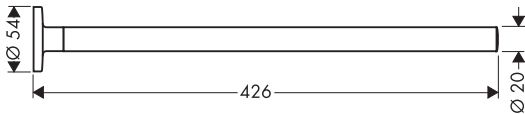

AXOR Uno
41560XXX

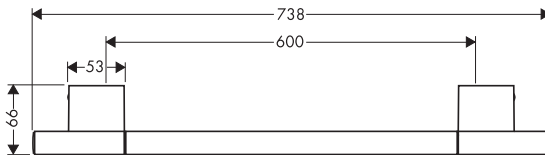

AXOR Uno
41580XXX

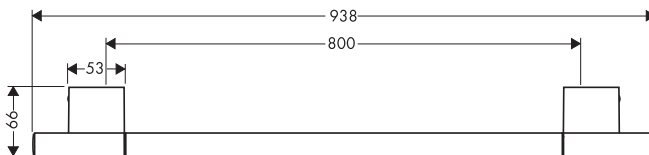

AXOR Uno
41521XXX

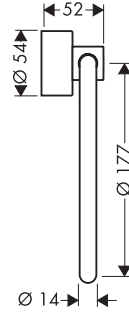

AXOR Uno
41528XXX

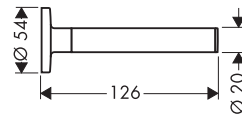

AXOR Uno
41533XXX

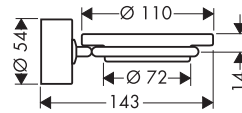

AXOR Uno
41534XXX

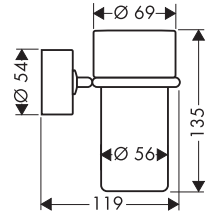

AXOR Uno
41535XXX

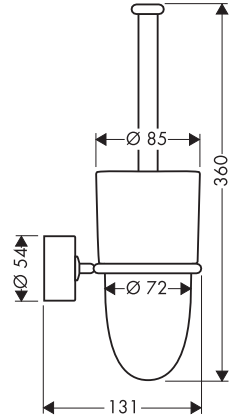

AXOR Uno
41536XXX

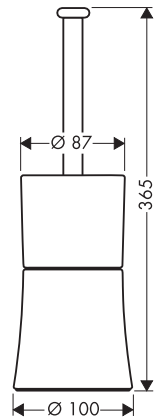

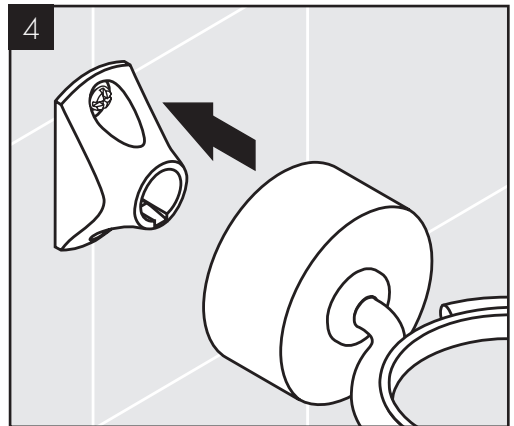
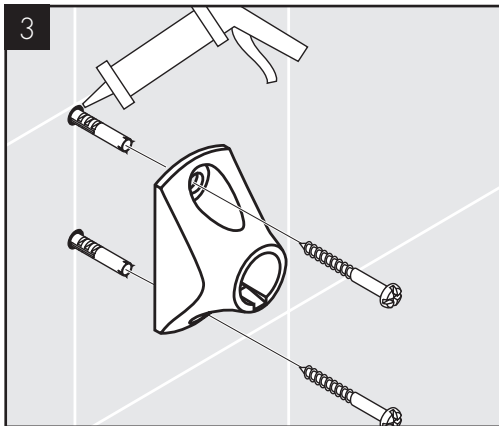
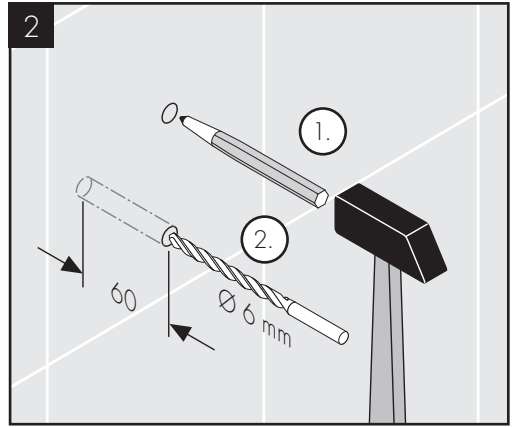
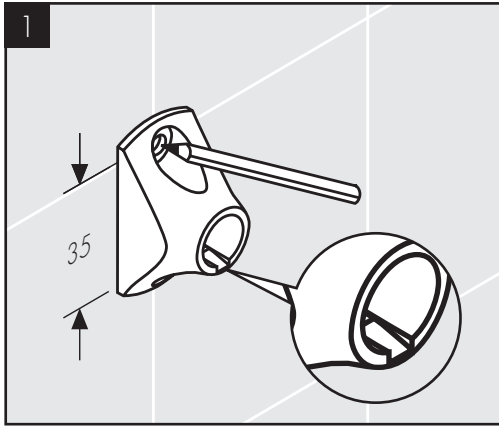

AXOR Uno 41520XXX / AXOR Uno 41528XXX

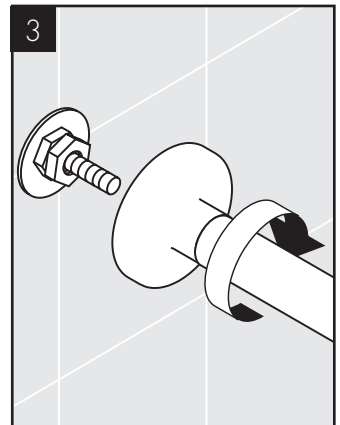
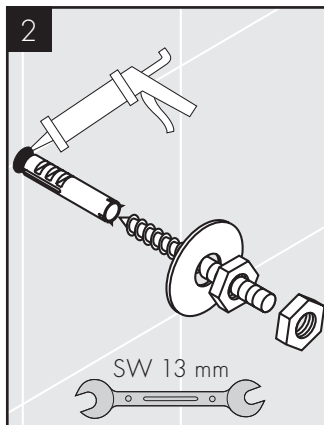
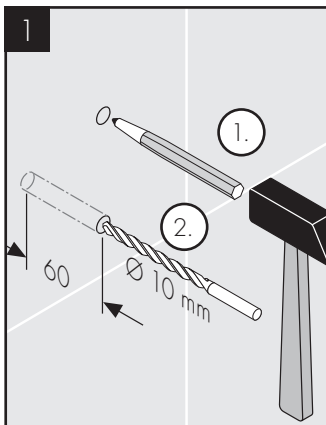

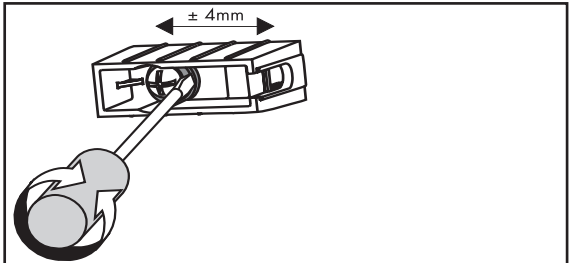
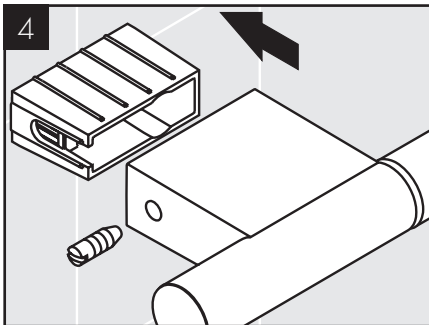
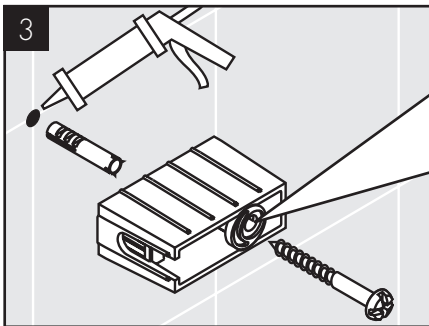
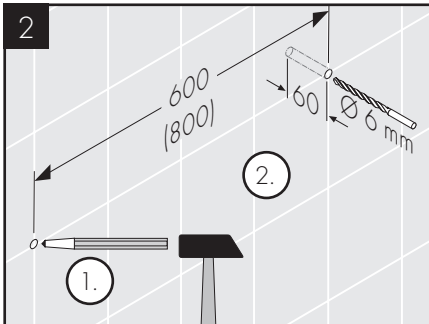
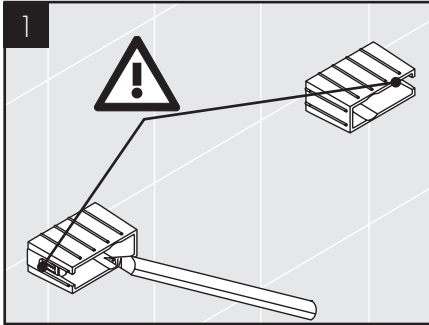

Durch die Exzenterbuchse können Bohrtoleranzen ausgeglichen werden. / Grâce à l'axe excentrique de réglage on peut rattraper la tolérance de perçage. / With the excentric washer it is possible to equalize tolerance of the drilling. / Con la rondella eccentrica è possibile equilibrare tolleranze diverse tra i fori. / Durante la instalación y mediante la excéntrica se puede corregir la posición de la barra. / Door de excentrische bus kunnen eventuele boorafwijkingen worden hersteld. / Ved hjælp af den excentriske bøsning kan evt. skævheder i borehullerne udlignes. / Com o encaixe excêntrico é possível compensar a tolerância da furação. / Za pomocą tulei mimośrodowej można łatwo wyrównać tolerancje otworów. / Excentrickými vložkami je možné vyrovnat tolerance vrtaných otvorů. / Excentrickými vložkami je možné vyrovnat' toleranciu vrtaných otvorov. / 用偏心套管可以补偿消除钻孔的偏差。 / С помощью соединения-эксцентрика можно установить штангу строго вертикально. / Az excenter hüvelynek köszönhetően a fúrásí egyenletlenségek kiegyenlíthetők. / Porautoleranssit voidaan tasata epäkeskokohteilla. / Boortoleranser kan utjämnas genom excenterhylsan. / Ekscentrinės jungties pagalba galima išlyginti išgręžtų angų nuokrypi. / Pomoću ekscentara mogu se podesiti tolerancije provrta. / Eksantrik burç ile delik toleransları dengelenebilir. / Compensaji diferentjele de găurit cu ajutorul bucșei excentrice. / Μέσω του κουτιού του εκκέντρου είναι δυνατή η εξισορρόπηση των ανοχών διάτρησης. / Z ekscentričnim vodilom lahko izravnate tolerance vrtanja. / Eksstentrilise vaheseibiga saab puurimisel tekkinud erinevusi tasakaalustada. / Ar ekscentra bukses palīdzību var izlīdzināt urbuma neprecizitātes. / Pomoću ekscentara mogu se podesiti tolerancije provrta. / Boretolanser kan utlignes ved hjælp af excenterbøsning. / Допустите при пробиване могат да се изравнят с эксцентричната втулка. / Pērmes kutisē ekscentrike mund tē ekvilibrohen tolerancat gjahtë shpimit. / باستخدام الحلقة اللامركزية يمكن معادلة خلوص الثقب.



- DE / Reinigungsempfehlung / Garantie / Kontakt
 FR / Recommandation pour le nettoyage / Garanties / Contact
 EN / Cleaning recommendation / Warranty / Contact
 IT / Raccomandazione di pulizia / Garanzia / Contatto
 ES / Recomendaciones para la limpieza / Garantía / Contacto
 NL / Aanbevelingen inzake reiniging / Garantie / Contact
 DK / Rensning, anbefaling / Garanti / Kontakt
 PT / Recomendações de limpeza / Garantia / Contacto
 PL / Zalecenie dotyczące pielęgnacji / Gwarancja / Kontakt
 CS / Doporučení k čištění / Záruka / Kontakt
 SK / Odporúčania pre čistenie / Záruka / Kontakt
 ZH / 清洁指南 / 担保 / 接触
 RU / Рекомендации по очистке / Гарантия / Контакты
 HU / Tisztítási tanácsok / Garancia / érintkezés
 FI / Puhdistussuositus / Takuu / Kosketus
 SV / Rengöringsrekommendationer / Garanti / Contacto
 LT / Valymo rekomendacijos / Garantija / Kontaktai
 HR / Preporuke za čišćenje / Garancija / Kontakt
 TR / Temizleme önerisi / Garanti / Temas
 RO / Recomandări pentru curățare / Garanție / Contact
 EL / Σύσταση καθαρισμού / Εγγύηση / επαφή
 SL / Priporočilo za čiščenje / Garancija / Kontakt
 ET / Puhastussuositused / Garantii / Kontakt
 LV / Tīrīšanas ieteikumi / Garantija / Kontakti
 SR / Preporuke za čišćenje / Garancija / Kontakt
 NO / Anbefaling for rengjøring / Garanti / Kontakt
 BG / Препоръка за почистване / Гаранция / Контакт
 SQ / Këshilla rreth pastrimit / Garancia / Kontakt
 KO / 세정시 권장사항 / 품질보증 / 접촉
 AR / توصيات التنظيف / الضمان (الولايات المتحدة الأمريكية) / اتصال

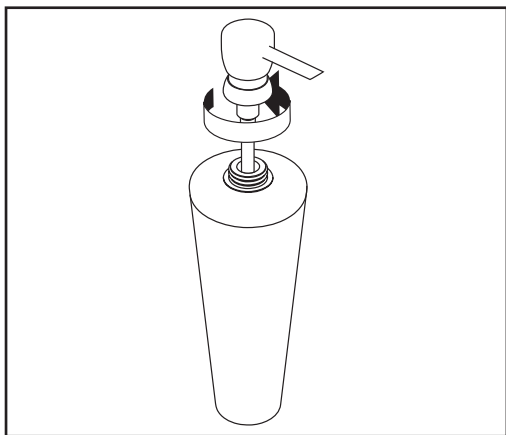

[www.axor-design.com/
cleaning-recommendation](http://www.axor-design.com/cleaning-recommendation)

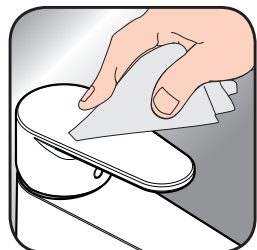

[www.axor-design.com/
cleaning-recommendation](http://www.axor-design.com/cleaning-recommendation)



[www.axor-design.com/
cleaning-recommendation](http://www.axor-design.com/cleaning-recommendation)



[www.axor-design.com/
cleaning-recommendation](http://www.axor-design.com/cleaning-recommendation)

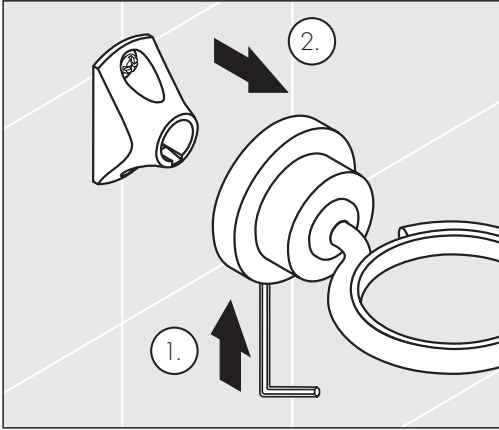

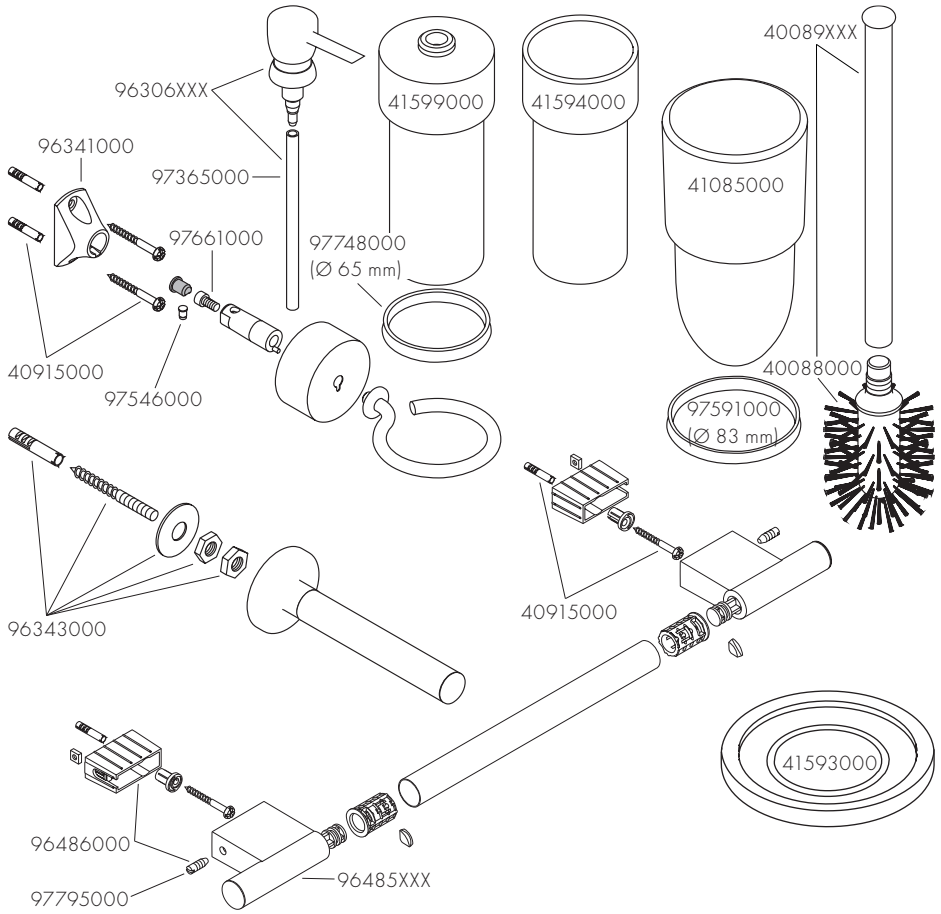

AXOR

AXOR / Hansgrohe SE
Austraße 5-9
77761 Schiltach
Deutschland

info@axor-design.com
axor-design.com

11/2019
9.08916.07