

Visign for Public equipment set
Instructions for Use



for urinal flushing system

Model
8326.65

Year built:
from 12/2014

en_INT



Table of contents

1	About these instructions for use	4
1.1	Target groups	4
1.2	Labelling of notes	4
1.3	About this translated version	5
2	Product information	6
2.1	Standards and regulations	6
2.2	Safety advice	6
2.3	Intended use	6
2.3.1	Areas of use	6
2.3.2	Maintenance	6
2.4	Product description	7
2.4.1	Overview	7
2.4.2	Technical data	7
2.4.3	Operating mode	7
2.4.4	System expansions	9
2.4.5	Setting options	10
3	Handling	12
3.1	Assembly information	12
3.1.1	Mounting conditions	12
3.1.2	Required material and tools	12
3.2	Assembly	13
3.2.1	Insert cartridge valve	13
3.2.2	Mounting the power pack	14
3.2.3	Mounting the basic panel	15
3.2.4	Mounting the flush plate	15
3.2.5	Connecting external sensors	17
3.3	Commissioning	18
3.3.1	Setting the infrared sensor	18
3.3.2	Setting the flush	19
3.3.3	Setting Hygiene+ function	21
3.4	Faults, faults and remedy	22
3.5	Care and maintenance	23
3.5.1	Maintenance tips	23
3.5.2	Cleaning cartridge valve	24
3.6	Disposal	27

1 About these instructions for use

Trade mark rights exist for this document, further information can be found at viega.com/legal.

1.1 Target groups

The information in this instruction manual is directed at the following groups of people:

- Heating and sanitary professionals and trained personnel
- Trained electricians
- Operators
- Consumers

It is not permitted for individuals without the abovementioned training or qualification to mount, install and, if required, maintain this product. This restriction does not extend to possible operating instructions.

The installation of Viega products must take place in accordance with the general rules of engineering and the Viega instructions for use.

1.2 Labelling of notes

Warning and advisory texts are set aside from the remainder of the text and are labelled with the relevant pictographs.

**DANGER!**

This symbol warns against possible life-threatening injury.

**WARNING!**

This symbol warns against possible serious injury.

**CAUTION!**

This symbol warns against possible injury.

**NOTICE!**

This symbol warns against possible damage to property.



Notes give you additional helpful tips.

1.3 About this translated version

This instruction for use contains important information about the choice of product or system, assembly and commissioning as well as intended use and, if required, maintenance measures. The information about the products, their properties and application technology are based on the current standards in Europe (e. g. EN) and/or in Germany (e. g. DIN/DVGW).

Some passages in the text may refer to technical codes in Europe/Germany. These should serve as recommendations in the absence of corresponding national regulations. The relevant national laws, standards, regulations, directives and other technical provisions take priority over the German/European directives specified in this manual: The information herein is not binding for other countries and regions; as said above, they should be understood as a recommendation.

2 Product information

2.1 Standards and regulations

The following standards and regulations apply to Germany / Europe. National regulations can be found on the relevant web site of your country at viega.com/standards.

Regulations from section: Technical data

Scope / Notice	Regulations applicable in Germany
Flush flow	DIN 3265
Noise class	DIN 4109

2.2 Safety advice



DANGER! Danger due to electrical current

An electric shock can lead to burns and serious injury and even death.

- Work on the electrics may only be carried out by trained electricians.
- Switch off the mains voltage before connecting the power pack.

2.3 Intended use

2.3.1 Areas of use

The equipment set is intended for the contact-free actuation of flushes in urinals.

Hygiene+ function

The Hygiene+ function actuates a flush after 24 hours without use to prevent stagnation in the drinking water lines.

2.3.2 Maintenance

The cartridge valve should be cleaned once a year to ensure fault-free operation. See ↗ *Chapter 3.5.2 „Cleaning cartridge valve“ on page 24*

2.4 Product description

2.4.1 Overview

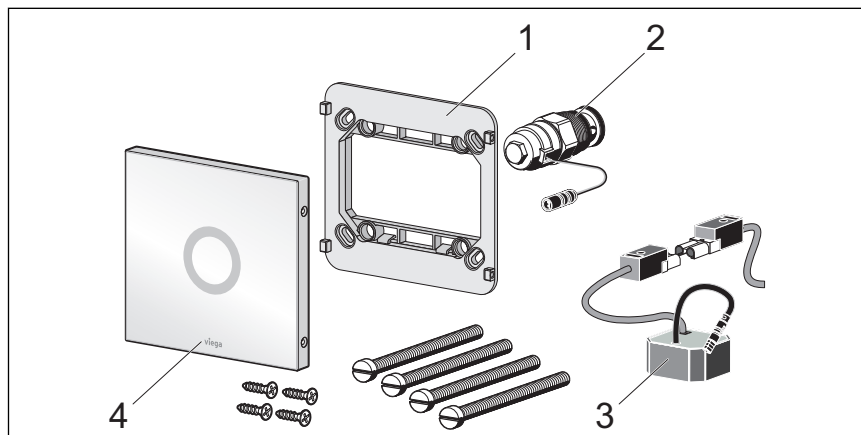

Fig. 1: Scope of delivery

- 1 - basic panel
- 2 - cartridge valve
- 3 - Power pack
- 4 - cover plate

2.4.2 Technical data

The product has the following technical data:

Operating voltage	Primary 100–240 V AC, 50–60 Hz, 180 mA Secondary 6 V DC/SELV
Magnetic coil	6 V
Flow pressure	0.05–0.5 MPa (0.5–5 bar)
Calculated flow	0.3 l/s
Flush flow, see ↗ „Regulations from section: Technical data“ on page 6	0.3–0.7 l/s
Noise class, see ↗ „Regulations from section: Technical data“ on page 6	2

2.4.3 Operating mode

Infrared actuation

Flush actuation takes place without contact via the infrared sensor on the flush plate.

The flush volume can be set in five stages.



In order to actuate a flush, a person must be within the detection area of the infrared sensor for at least 8 seconds.



If a person leaves the detection area, a flush is automatically actuated. Depending on the setting, the flush duration is between 1 and 20 seconds.



A flush cycle can also be manually actuated by placing a hand in front of the sensor during the first 8 seconds.

Hygiene+ function

Stagnation can lead to the build up of germs (e. g. legionella) in drinking water pipes. It is important to rinse the pipeline regularly to prevent the build up of bacteria. The Viega Hygiene+ function was developed for this reason.

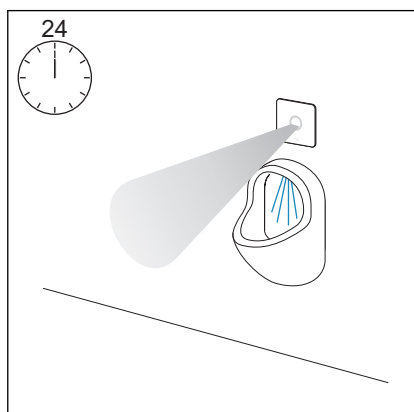

The Hygiene+ function automatically actuates a Hygiene flush after 24 hours without use. The Hygiene flush volume can be set in five stages.

2.4.4 System expansions

The system's range of functions can be expanded through the connection of accessories onto the control.

Additional external sensors

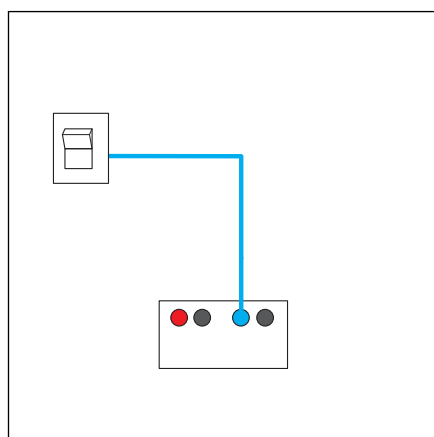
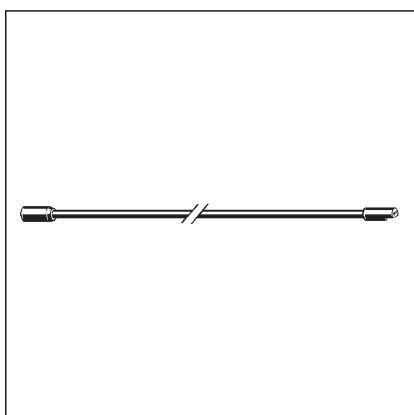

Fig. 2: Connection of an external sensor

Buttons, switches or photo sensors for triggering the flush can be connected to the control on site via the extension cable model 2241.95.

The cartridge valve remains open as long as the contact via the extension cable is closed.

The overflow protection prevents that the cartridge valve remains open for longer than a minute. The contact must be re-opened to enable a further flush.



battery compartment

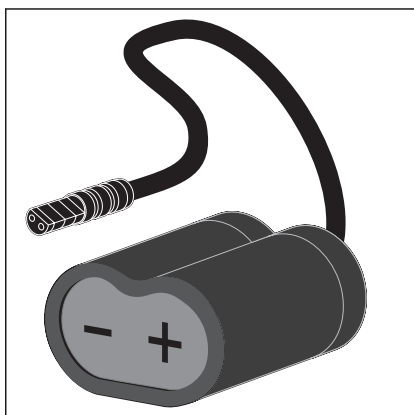

The battery compartment model 8351.11 (article number 731 786) can also be connected as an alternative to the power pack.

2.4.5 Setting options

Settings for the infrared sensor

Range of the infrared sensor

The following settings are possible:

- Close range, so that the flush cannot be inadvertently actuated.
- Medium range from approx. 450 mm. This setting is the factory setting.
- Far range, so that the automatic actuation of a flush also works at a greater distance from the urinal.

Manual flush in close range

If this option is activated, a flush can be actuated in the first 8 seconds of entering the detection area by placing a hand in front of the sensor.

Lid in front of sensor

This setting is for the case that an open lid covers the sensor. The function is deactivated in the factory settings. If the function is activated, a flush cycle is actuated as soon as the lid is removed from the sensor zone.

However, during planning, we still recommend that the lid is not placed in front of the sensor in order to ensure the device works perfectly.

Flush settings

Flush duration

This setting is intended exclusively for the flush duration for the directly actuated flushes. The flush duration for hygiene flushes is set separately.

The flush duration can be set in 5 steps to reach the required flush volume.

Hygiene flush

The setting determines if a hygiene flush is actuated after 24 hours without use.

Flush duration hygiene flush

The flush duration of the hygiene flush can be set in 5 steps to reach the required flush volume.

3 Handling

3.1 Assembly information

3.1.1 Mounting conditions

External sensors (optional)

If external sensors are to be connected to the control, their connection lines must be laid through to the revision opening before tiling is begun.

Minimum intervals

The following minimum distances must be complied with to ensure the infrared sensor works perfectly:

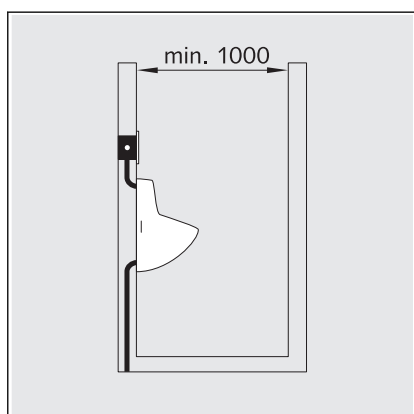

A minimum distance of 1000 mm must be maintained to the opposite walls.

If high-gloss wall claddings (polished tiles, mirrors, etc.) are situated opposite, the minimum distance must be increased to 1500 mm.

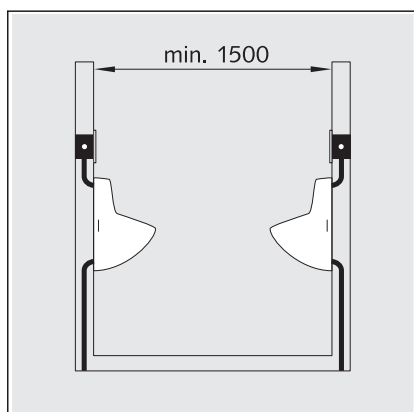

A minimum distance of 1500 mm must be maintained to urinals situated opposite with infrared sensors.

3.1.2 Required material and tools

Tool

The following tools are required for mounting:

- flat screwdriver
- Torx screwdriver (T 10)
- spanner (SW 17)
- spanner (SW 32)

3.2 Assembly

3.2.1 Insert cartridge valve

Requirements:

- the pre-wall element has been mounted
 - the revision opening is freely accessible
 - the tiling work is completed.
- Open the shut-off with a screw driver for a few seconds to rinse the pipeline.
 - Re-close shut-off.

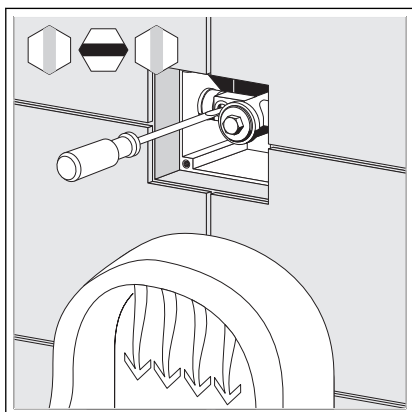

- Remove seal (SW 17).

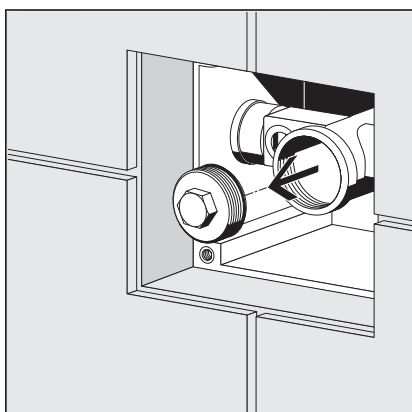

- Place the cartridge valve on straight and carefully screw in (fine thread).
- Screw in cartridge valve (SW 32).

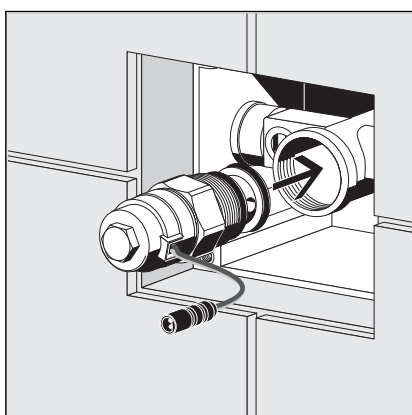

3.2.2 Mounting the power pack



DANGER!
Danger due to electrical current

An electric shock can lead to burns and serious injury and even death.

- Work on the electrics may only be carried out by trained electricians.
- Always de-energise the connection line before work is commenced.

Requirements:

- A 230 V mains connection is available on site.
- The connection pipeline is de-energised.
- Remove approx. 1 cm of the insulation on the connection pipelines.

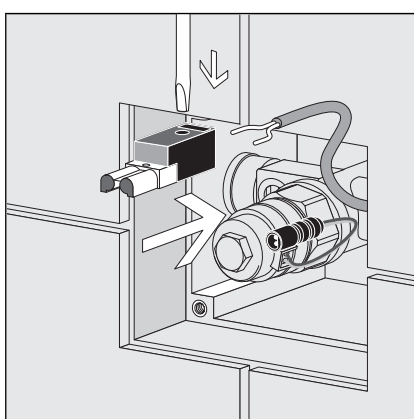
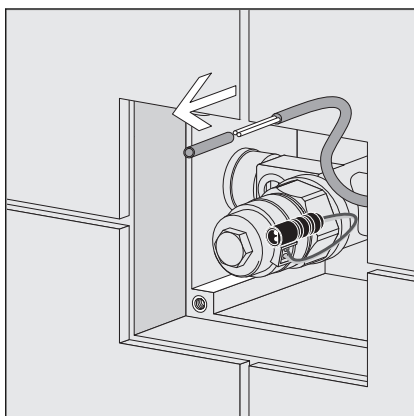

- Push the connection pipelines into the clamps and screw on.

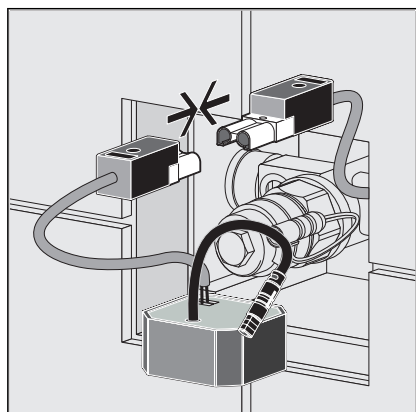

- Connect the clamps of the connection pipelines and power pack.

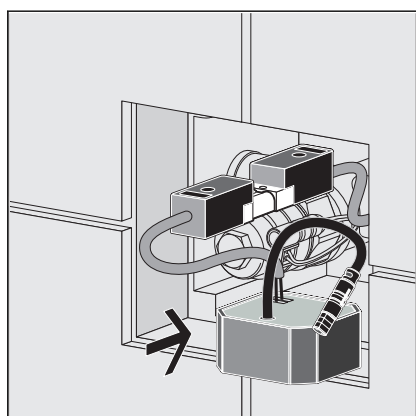

- Push the power pack into the revision opening.

3.2.3 Mounting the basic panel

In the next step, the basic panel of the flush plate must be mounted.

Requirements:

- The cartridge valve is mounted.
- The power pack is connected
- Align basic panel horizontally and screw together.

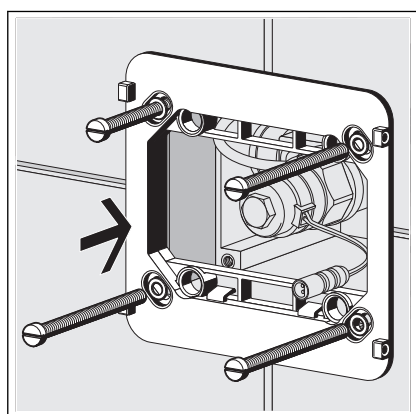

3.2.4 Mounting the flush plate



Observation of the prescribed connection sequence is required. The power supply must always be connected last, to ensure that all of the connected components function.

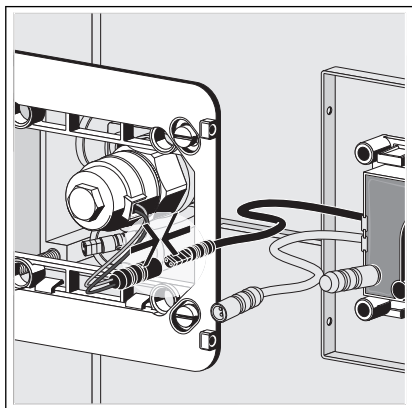

- Connect the cartridge valve to the control.

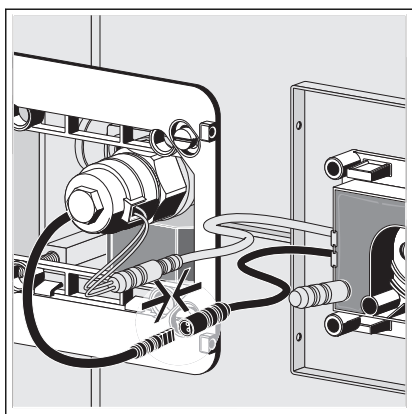

- If required, additional external sensors can be connected to the control. See [Chapter 3.2.5 „Connecting external sensors“](#) on page 17.
- Connect the power pack to the control.
 - ⇒ The infrared sensor is calibrated for approx. 10 seconds. While calibrating, ensure you are stood to the side of the panel so that you are not in the sensor's detection area.

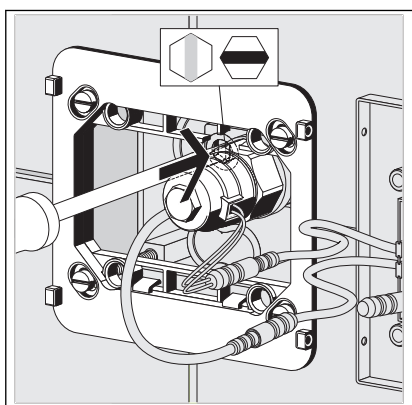

- Open shut-off with a screwdriver.

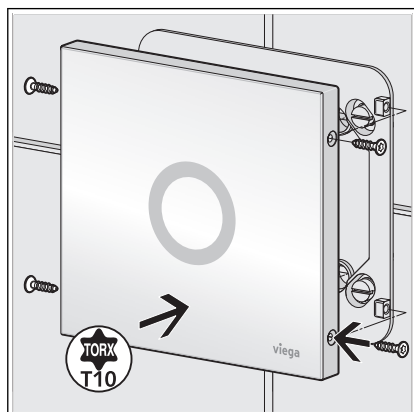

- Screw cover plate onto the basic panel.

3.2.5 Connecting external sensors



NOTICE!

Damage to property due to excess voltage

If you apply voltage to the connection cable for the external button, you will damage the control.

- Do not apply any external voltage!

Requirements:

- On site button with closing function or potential-free contact available
- Extension cable model 2241.95 available
- Remove the jack from the extension cable model 2241.95.
- Connect the contact to actuate the flush cycle to the extension cable.

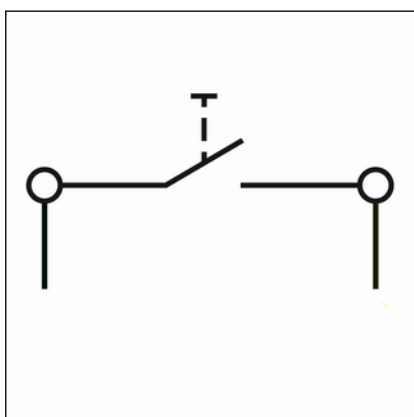

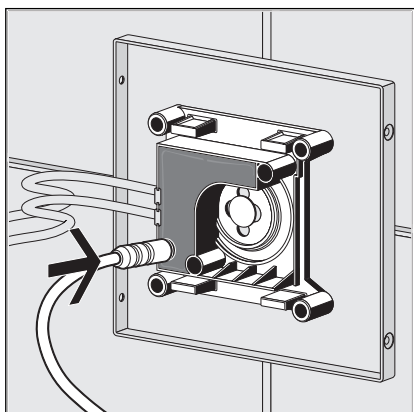

➤ Connect the extension cable to the control.

➤ Continue with the mounting of the flush plate. See [Chapter 3.2.4](#) „Mounting the flush plate“ on page 15.

3.3 Commissioning

3.3.1 Setting the infrared sensor

Programming block

Programming the control can be carried out for 30 minutes after the supply voltage is applied. The control returns to normal operation after 30 minutes – programming is now blocked. If the settings have to be changed after this time, the control must be disconnected from the power supply for at least 10 seconds.



Observe the following features during programming:

- Only one value can be set per programming step.
- The settings are retained, even if there is an interruption in the power supply.
- The programming procedure can be interrupted without changing the settings by covering the infrared sensor until the flashing signal has stopped for more than 2 seconds.

Programming the settings

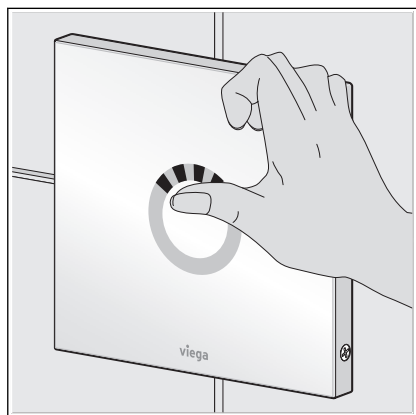

Requirements:

- The control programming block is not active.
- Cover the top part of the infrared ring. (e. g. with a finger or a hand).
 - ⇒ The LED blinks twice after 10 seconds. Programming mode is active.

- The following values can be set by removing the hand:

Remove hand after	Setting
12. blinking signal	close range set
13. blinking signal	medium range set (factory setting)
14. blinking signal	long range set
15. blinking signal	function "Manual flush in close range" ON
16. blinking signal	function "Manual flush in close range" OFF (factory setting)
17. blinking signal	function "Urinal cover in front of sensor" ON
18. blinking signal	function "Urinal cover in front of sensor" OFF (factory setting)

- ⇒ The LED flashes twice to confirm the setting.

3.3.2 Setting the flush

Programming the settings

Using the guide values from the table below, you can determine the flush volume on the basis of flow pressure and flush duration:

Flow pressure	flush duration 2 seconds	flush duration 5 seconds	flush duration 10 seconds	flush duration 15 seconds	flush duration 20 seconds
0.1 MPa (1 bar)	0.5 l	1.2 l	2.1 l	3.1 l	4.1 l
0.2 MPa (2 bar)	0.7 l	1.6 l	3 l	4.5 l	5.9 l
0.3 MPa (3 bar)	0.9 l	2 l	3.7 l	5.4 l	7.2 l
0.4 MPa (4 bar)	1 l	2.3 l	4.3 l	6.3 l	8.3 l
0.5 MPa (5 bar)	1.2 l	2.6 l	4.8 l	7 l	9 l

Requirements:

- The control programming block is not active.
- Cover the top part of the infrared ring. (e. g. with a finger or a hand).
 - ⇒ The LED blinks twice after 10 seconds. Programming mode is active.

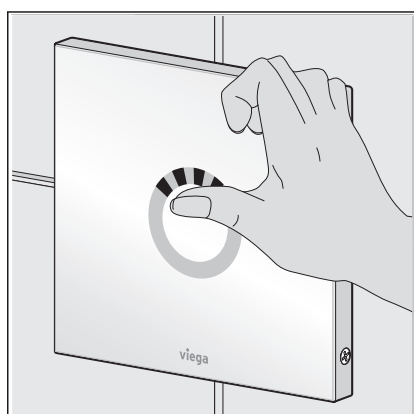

- The following values can be set by removing the hand:

Remove hand after	Setting
1st blinking signal	flush duration approx. 2 seconds
2nd blinking signal	flush duration approx. 5 seconds
3rd blinking signal	flush duration approx. 10 seconds (factory setting)
4th blinking signal	flush duration approx. 15 seconds
5th blinking signal	flush duration approx. 20 seconds

- ⇒ The LED flashes twice as confirmation of the setting.

3.3.3 Setting Hygiene+ function

Programming the settings

You can define the hygiene flush volume on the basis of the flow pressure and flush duration using the values in the table:

Flow pressure	flush duration 2 seconds	flush duration 5 seconds	flush duration 10 seconds	flush duration 15 seconds	flush duration 20 seconds
0.1 MPa (1 bar)	0.5 l	1.2 l	2.1 l	3.1 l	4.1 l
0.2 MPa (2 bar)	0.7 l	1.6 l	3 l	4.5 l	5.9 l
0.3 MPa (3 bar)	0.9 l	2 l	3.7 l	5.4 l	7.2 l
0.4 MPa (4 bar)	1 l	2.3 l	4.3 l	6.3 l	8.3 l
0.5 MPa (5 bar)	1.2 l	2.6 l	4.8 l	7 l	9 l

Requirements:

- The control programming block is not active.
- Cover the top part of the infrared ring (e. g. with a finger or a hand).
 - ⇒ The LED blinks twice after 10 seconds. Programming mode is active.

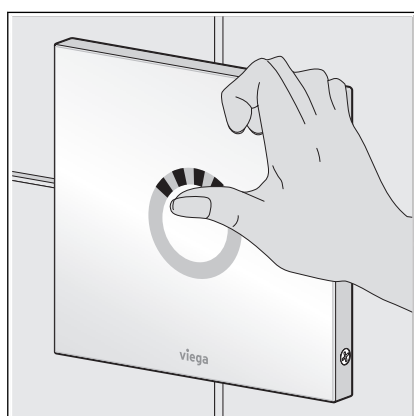

► The following values can be set by removing the hand:

Remove hand after	Setting
6th blinking signal	Hygiene flush OFF
7th blinking signal	flush duration approx. 2 seconds
8th blinking signal	flush duration approx. 5 seconds (factory setting)
9th blinking signal	flush duration approx. 10 seconds
10th blinking signal	flush duration approx. 15 seconds
11th blinking signal	flush duration approx. 20 seconds

⇒ The LED flashes twice to confirm the setting.

3.4 Faults, faults and remedy

Error	Cause	Remedy
Urinal does not flush	no supply voltage	check plug connections
	Shut-off valve closed	Open shut-off valve
	Sensor field dirty or damaged	Clean cover plate, if necessary, replace ↗ <i>Chapter 3.5.1 „Maintenance tips“ on page 23</i>
	Cartridge valve dirty or damaged	Clean cartridge valve, if necessary, replace ↗ <i>Chapter 3.5.2 „Cleaning cartridge valve“ on page 24</i>
	Control defect	Replace base frame
	The red LED flashes quickly during the first minute after commissioning, although there is no-one in the sensor detection area. Infrared sensor detection area too large.	Reduce detection area ↗ <i>Chapter 3.3.2 „Setting the flush“ on page 19</i>
	The red LED flashes in the first minute after commissioning. The flashing does not become quicker even though there is someone in the detection area. Infrared sensor detection area too small.	Increase detection area ↗ <i>Chapter 3.3.2 „Setting the flush“ on page 19</i>
Flush is too weak	Shut-off valve is not open far enough	Open shut-off valve

Error	Cause	Remedy
	Flow pressure too high	maximum flow pressure 0.5 MPa (5 bar)
	Flushing time too short	Set flushing time ↪ Chapter 3.3.2 „Setting the flush“ on page 19
	Cartridge valve dirty or damaged	Clean cartridge valve, if necessary, replace ↪ Chapter 3.5.2 „Cleaning cartridge valve“ on page 24
Urinal flush runs through	Components are fitted in the wrong order	Separate the plug connections and wait 10 seconds. Re-connect the cartridge valve then the power supply.
	Shut-off valve is not open far enough	Open shut-off valve minimum flow pressure 0.05 MPa (0.5 bar)
	Cartridge valve dirty or damaged	Clean cartridge valve, if necessary, replace ↪ Chapter 3.5.2 „Cleaning cartridge valve“ on page 24
	Control defect	Replace base frame

3.5 Care and maintenance

3.5.1 Maintenance tips

Normal soap or a mild cleaning agent can be used for regular care and prevention of lime scale on the flush plate. Under no circumstances should scouring agent or scratching objects be used.

Strong stains can be removed using typical household cleaner. Rinse the detergent thoroughly with clear water after the prescribed exposure time. There should be no residue on the components.

Deactivate flush plate for cleaning

To clean the flush plate, the flush actuation function can be briefly deactivated.



Deactivation only becomes possible 30 minutes after connecting the power supply.

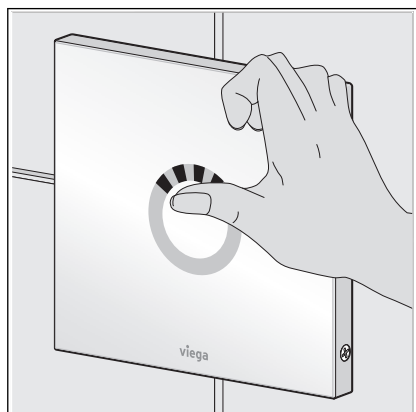

- Cover the top part of the infrared ring.
 - ⇒ The LED blinks twice after 10 seconds.
 - The LED blinks again after a further 2 seconds.

- Remove the cover from the infrared ring within 2 seconds.
 - ⇒ The LED blinks twice.
 - The flush actuation is deactivated for 10 minutes. The LED is lit during this time.
- Clean flush plate.
 - ⇒ The LED goes out after 10 minutes and a flush is actuated.
 - The flush actuation is active again.

3.5.2 Cleaning cartridge valve

The cartridge valve may be cleaned, if necessary. Proceed as follows:

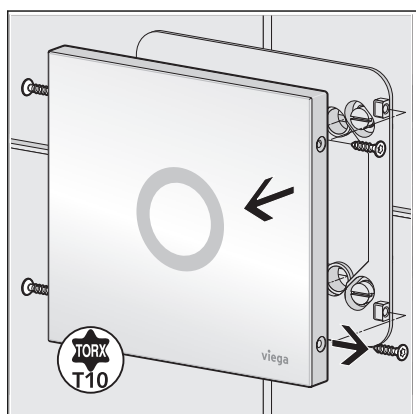

- Unscrew the cover plate from the basic panel.

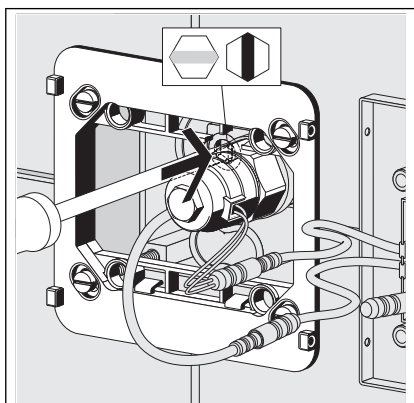

➤ Close shut-off.

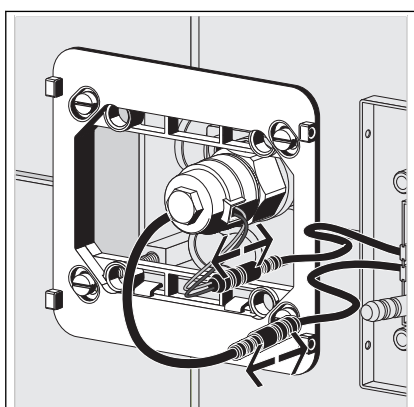

➤ Disconnect cartridge valve and power supply from the control.

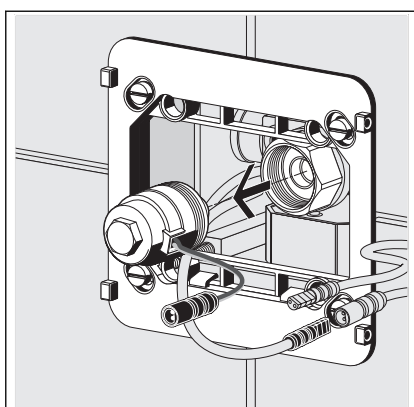

➤ Unscrew cartridge valve.

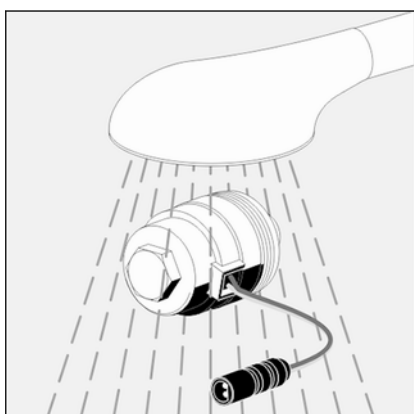

➤ Rinse cartridge valve under running water.
Remove coarse dirt with a soft brush.

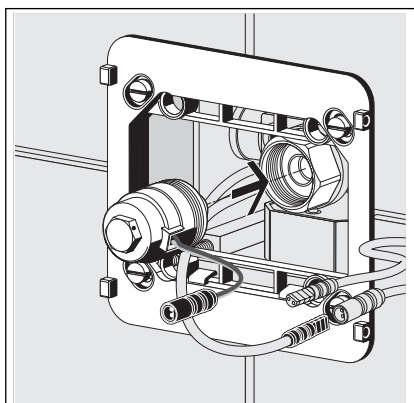

- Place the cartridge valve on straight and carefully screw in (fine thread).
- Screw in cartridge valve (SW 32).

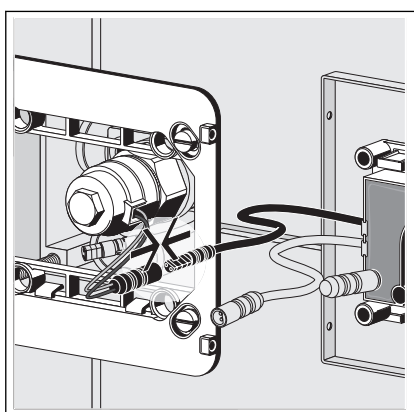

- Connect the cartridge valve to the control.

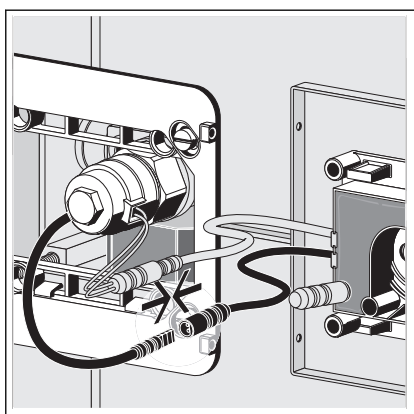

- Connect the power pack to the control.
 - ⇒ The infrared sensor is calibrated for approx. 10 seconds. While calibrating, ensure you are stood to the side of the panel so that you are not in the sensor's detection area.

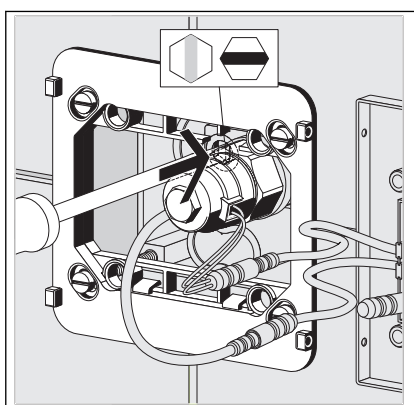

- Open shut-off with a screwdriver.

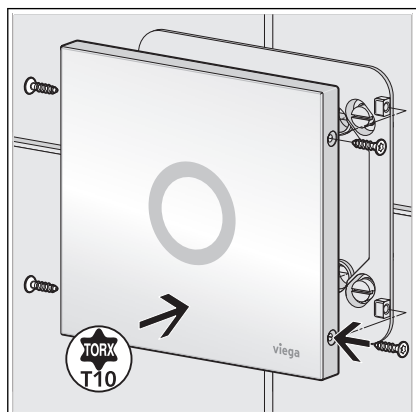

► Screw cover plate onto the basic panel.

3.6 Disposal

Separate the product and packaging materials (e. g. paper, metal, plastic or non-ferrous metals) and dispose of in accordance with valid national legal requirements.