

## Novus

Single lever basin mixer for exposed installation with extra long handle

Surfaces: **Chrome** Article Number: **71923000**



### Description

#### product features

- larger print for greater clarity
- with extra long barrier-free handle
- projection 192 mm
- centre distance: 150 ± 12 mm
- normal spray
- flow rate at 3 bar: 5 l/min
- ceramic cartridge
- temperature limitation adjustable
- with noise reduction
- suitable for continuous flow water heaters
- connection type: s-shaped connections
- connection dimension: DN15

### Technology



### Product image



### Scale drawing

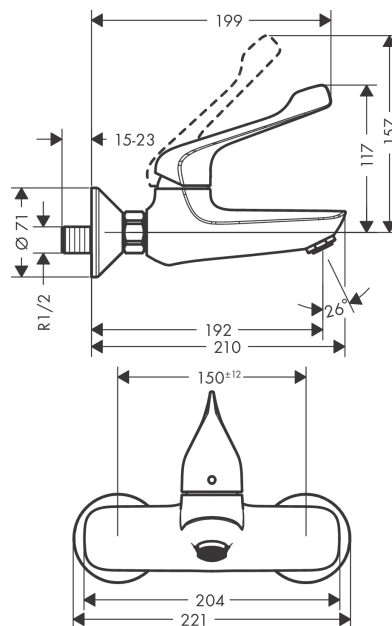

### Flowchart

