

DE	Montageanleitung	2
FR	Instructions de montage	3
EN	assembly instructions	4
IT	Istruzioni per Installazione	5
ES	Instrucciones de montaje	6
NL	Handleiding	7
DK	Monteringsvejledning	8
PT	Manual de Instalação	9
PL	Instrukcja montażu	10
CS	Montážní návod	11
SK	Montážny návod	12
ZH	组装说明	13
RU	Инструкция по монтажу	14
HU	Szerelési útmutató	15
FI	Asennusohje	16
SV	Monteringsanvisning	17
LT	Montavimo instrukcijos	18
HR	Uputstva za instalaciju	19
TR	Montaj kılavuzu	20
RO	Instrucțiuni de montare	21
EL	Οδηγία συναρμολόγησης	22
SL	Navodila za montažo	23
ET	Paigaldusjuhend	24
LV	Montāžas instrukcija	25
SR	Uputstvo za montažu	26
NO	Montasjeveiledning	27
BG	Ръководство за монтаж	28
SQ	Udhëzime rreth montimit	29
AR	دليل الاستخدام	30

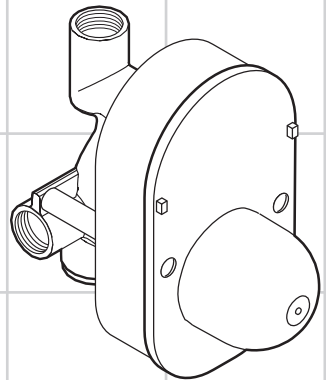

31741180



Sicherheitshinweise

- Bei der Montage müssen zur Vermeidung von Quetsch- und Schnittverletzungen Handschuhe getragen werden.
- Große Druckunterschiede zwischen den Kalt- und Warmwasseranschlüssen müssen ausgeglichen werden.

Montagehinweise

- Vor der Montage muss das Produkt auf Transportschäden untersucht werden. Nach dem Einbau werden keine Transport- oder Oberflächenschäden anerkannt.
- Die Leitungen und die Armatur müssen nach den gültigen Normen montiert, gespült und geprüft werden.
- Die in den Ländern jeweils gültigen Installationsrichtlinien sind einzuhalten.
- Die Armatur muss isoliert und schallentkoppelt montiert werden.

Montage (siehe Seite 31)

Grundkörper so einbauen, dass sich der G 3/4 Anschluss unten befindet.

Einbautiefe 68 mm bis 96 mm.

Verlängerungsset 28 mm

Achten Sie darauf, dass der Mischer nach Beendigung der Montage geschlossen ist!

- A** Installation auf die Wand.
- B** Installation vor der Wand. Hier mit variablen Abstandshaltern durch Stockschrauben M 10.
- C** Installation direkt in die Wand.

Technische Daten

Betriebsdruck:	max. 1 MPa
Empfohlener Betriebsdruck:	0,1 - 0,5 MPa
Prüfdruck:	1,6 MPa
(1 MPa = 10 bar = 147 PSI)	
Heißwassertemperatur:	max. 70 °C
Empfohlene Heißwassertemperatur:	65 °C
Anschlüsse G 1/2:	kalt rechts - warm links

Das Produkt ist ausschließlich für Trinkwasser konzipiert!

Symbolerklärung



Kein essigsäurehaltiges Silikon verwenden!



Justierung (siehe Seite 32)

Einstellen der Warmwasserbegrenzung. In Verbindung mit Durchlauferhitzern ist eine Warmwassersperre nicht zu empfehlen.



Maße (siehe Seite 33)



Durchflussdiagramm

(siehe Seite 33)

- ① Abgang Wanne
- ② Abgang Brause



Endmontage (siehe Seite 35)



Serviceteile (siehe Seite 34)

Sonderzubehör (nicht im Lieferumfang enthalten)



Verlängerungsset 28 mm #32498000



Prüfzeichen (siehe Seite 40)



Montage siehe Seite 31



Consignes de sécurité

- ⚠ Lors du montage, porter des gants de protection pour éviter toute blessure par écrasement ou coupure.
- ⚠ Il est conseillé d'équilibrer les pressions de l'eau chaude et froide.

Instructions pour le montage

- Avant son montage, s'assurer que le produit n'a subi aucun dommage pendant le transport. Après le montage, tout dommage de transport ou de surface ne pourra pas être reconnu.
- Les conduites et la robinetterie doivent être montés, rincés et contrôlés selon les normes en vigueur.
- Les directives d'installation en vigueur dans le pays concerné doivent être respectées.
- La robinetterie doit être montée de façon isolée et insonorisée.

Montage (voir pages 31)

Encastrez le corps de telle manière à ce que le raccord G 3/4 soit orienté vers le bas.

Profondeur d'encastrement: 68 mm à 96 mm.
rallonge 28 mm

A la fin du montage, vérifier que le mitigeur est bien fermé!

- A** Installation au mur.
- B** Installation contre le mur avec entretoise.
- C** Installation directement dans le mur.

Informations techniques

Pression de service autorisée:	max. 1 MPa
Pression de service conseillée:	0,1 - 0,5 MPa
Pression maximum de contrôle:	1,6 MPa
(1 MPa = 10 bar = 147 PSI)	
Température d'eau chaude:	max. 70°C
Température recommandée:	65°C
Raccordement G 1/2:	froide à droite - chaude à gauche

Le produit est exclusivement conçu pour de l'eau potable!

Description du symbole



Ne pas utiliser de silicone contenant de l'acide acétique!



Étalonnage (voir pages 32)

Réglage de la limitation d'eau chaude. En liaison avec les chauffe-eau, un blocage de l'eau chaude n'est pas recommandable.



Dimensions (voir pages 33)



Diagramme du débit

(voir pages 33)

- ① Sortie baignoire
- ② Sortie douche



Finition (voir pages 35)



Pièces détachées (voir pages 34)



Accessoires en option (ne fait pas partie de la fourniture)

rallonge 28 mm #32498000



Classification acoustique et débit (voir pages 40)



Montage voir pages 31



Safety Notes

- △ Gloves should be worn during installation to prevent crushing and cutting injuries.
- △ The hot and cold supplies must be of equal pressures.

Installation Instructions

- Prior to installation, inspect the product for transport damages. After it has been installed, no transport or surface damage will be honoured.
- The pipes and the fixture must be installed, flushed and tested as per the applicable standards.
- The plumbing codes applicable in the respective countries must be observed.
- The fittings must be mounted in an insulated manner and with sound insulation.

Assembly (see page 31)

Install body with G 3/4 outlet pointing downwards.

Depth of fitting: 68 mm to 96 mm.

extension set 28 mm

Note: When installation is complete ensure that the mixer is turned off!

- A** Direct wall installation.
- B** Direct wall installation with 10 mm adjustable mounting studs.
- C** Brick wall installation.

Technical Data

Operating pressure:	max. 1 MPa
Recommended operating pressure:	0,1 - 0,5 MPa
Test pressure:	1,6 MPa
(1 MPa = 10 bar = 147 PSI)	
Hot water temperature:	max. 70°C
Recommended hot water temp.:	65°C
Connections G 1/2:	cold right - hot left

The product is exclusively designed for drinking water!

Symbol description



Do not use silicone containing acetic acid!



Adjustment (see page 32)

To adjust the hot water limiter. Using a hot water limiter in combination with a continuous flow water heater is not recommended.



Dimensions (see page 33)



Flow diagram

(see page 33)

- ① Tub outlet
- ② Shower outlet



Final assembly (see page 35)



Spare parts (see page 34)



Special accessories (order as an extra)

extension set 28 mm #32498000





Test certificate (see page 40)



Assembly see page 31



Indicazioni sulla sicurezza

-  Durante il montaggio, per evitare ferite da schiacciamento e da taglio bisogna indossare guanti protettivi.
-  **Attenzione!** Compensare le differenze di pressione tra i collegamenti dell'acqua fredda e dell'acqua calda.

Istruzioni per il montaggio

- Prima del montaggio è necessario controllare che non ci siano stati danni durante il trasporto. Una volta eseguito il montaggio, non verranno riconosciuti eventuali danni di trasporto o delle superfici.
- Montare, lavare e controllare tubature e rubinetteria rispettando le norme correnti.
- Vanno rispettate le direttive di installazione nazionali vigenti nel rispettivo paese.
- Il rubinetto deve essere installato isolato e disaccoppiato dai rumori.

Montaggio (vedi pagg. 31)

Installare il corpo ad incasso in modo che l'attacco G 3/4 sia rivolto verso il basso.

Profondità d'installazione: da 68 mm a 96 mm.
prolunga 28 mm

Assicurarsi che alla fine del montaggio il miscelatore sia chiuso!

- A** Installazione a muro.
- B** Installazione sul muro. Qui con distanziali (viti da 10 mm).
- C** Installazione diretta a muro.

Dati tecnici

Pressione d'uso:	max. 1 MPa
Pressione d'uso consigliata:	0,1 - 0,5 MPa
Pressione di prova:	1,6 MPa
(1 MPa = 10 bar = 147 PSI)	
Temperatura dell'acqua calda:	max. 70°C
Temp. dell'acqua calda consigliata:	65°C
Raccordi G 1/2:	fredda a destra - calda a sinistra

Il prodotto è concepito esclusivamente per acqua potabile!

Descrizione simbolo



Non utilizzare silicone contenente acido acetico!



Taratura (vedi pagg. 32)

Regolazione del limitatore di erogazione d'acqua calda. Un limitatore di erogazione di acqua calda in combinazione con le caldaie istantanee non è consigliabile.



Ingombri (vedi pagg. 33)



Diagramma flusso

(vedi pagg. 33)

- ① uscita vasca
- ② uscita doccia



Montaggio finale (vedi pagg. 35)



Parti di ricambio (vedi pagg. 34)



Accessori speciali (non contenuto nel volume di fornitura)

prolunga 28 mm #32498000



Segno di verifica (vedi pagg. 40)



Montaggio vedi pagg. 31



Indicaciones de seguridad

- ⚠ Durante el montaje deben utilizarse guantes para evitar heridas por aplastamiento o corte.
- ⚠ Grandes diferencias de presión en servicio entre agua fría y agua caliente deben equilibrarse.

Indicaciones para el montaje

- Antes del montaje se debe examinar el producto contra daños de transporte. Después de la instalación no se reconoce ningún daño de transporte o de superficie.
- Los conductos y la grifería deben montarse, lavarse y comprobarse según las normas vigentes.
- Es obligatorio el cumplimiento de las directrices de instalación vigentes en el país respectivo.
- El grifo debe ser instalado con aislamiento y desacoplamiento acústico.

Montaje (ver página 31)

Montar el cuerpo con la conexión de entrada G 3/4 hacia abajo.

Profundidad de montaje 68 mm a 96 mm.

Prolongación 28 mm

Atención, el mezclador monomando después del montaje debe quedar cerrado!

- A** Instalación directamente sobre la pared.
- B** Instalación sobre la pared. Aquí con soportes de distanciamiento y tornillos de acero de 10.
- C** Instalación directa en la pared.

Datos técnicos

Presión en servicio:	max. 1 MPa
Presión recomendada en servicio:	0,1 - 0,5 MPa
Presión de prueba:	1,6 MPa
(1 MPa = 10 bar = 147 PSI)	
Temperatura del agua caliente:	max. 70°C
Temp. recomendada del agua caliente:	65°C
Racores excéntricos G 1/2:	a la derecha frío - a la izquierda caliente

El producto ha sido concebido exclusivamente para agua potable.

Descripción de símbolos



No utilizar silicona que contiene ácido acético!



Ajuste (ver página 32)

Ajuste del límite de agua caliente. En combinación con calentadores continuos no es recomendable utilizar un bloqueo de agua caliente.



Dimensiones (ver página 33)



Diagrama de circulación

(ver página 33)

- ① Salida bañera
- ② Salida surtidor de ducha



Montaje final (ver página 35)



Repuestos (ver página 34)



Opcional (no incluido en el suministro)

Prolongación 28 mm #32498000



Marca de verificación (ver página 40)



Montaje ver página 31



Veiligheidsinstructies

- ⚠ Bij de montage moeten ter voorkoming van knel- en snijwonden handschoenen worden gedragen.
- ⚠ Grote drukverschillen tussen de koud- en warmwater-toevoer dienen vermeden te worden.

Montage-instructies

- Vóór de montage moet het product gecontroleerd worden op transportschade. Na de inbouw wordt geen transport- of oppervlakteschade meer aanvaard.
- De leidingen en armaturen moeten gemonteerd, gespoeld en gecontroleerd worden volgens de geldige normen.
- De in de overeenkomstige landen geldende installatie-richtlijnen moeten nageleefd worden.
- De armatuur moet geïsoleerd en geluidsontkoppeld gemonteerd worden.

Montage (zie blz. 31)

Basisgarnituur inbouwen met de G 3/4 aansluiting naar beneden.

Inbouwdiepte 68 mm tot 96 mm.
verlengset

Let u erop dat de kraan na montage gesloten is!

- A** Installatie voor de wand.
- B** Installatie voor de wand.
- C** Installatie in de wand.

Technische gegevens

Werkdruk: max.	max. 1 MPa
Aanbevolen werkdruk:	0,1 - 0,5 MPa
Getest bij:	1,6 MPa
(1 MPa = 10 bar = 147 PSI)	
Temperatuur warm water:	max. 70°C
Aanbevolen warm water temp.:	65°C
Aansluitingen G 1/2:	koud rechts - warm links

Het product is uitsluitend ontworpen voor drinkwater!

Symboolbeschrijving



Gebruik geen zuurhoudende siliconen!



Instellen (zie blz. 32)

Instellen van de warmwaterbegrenzing. In combinatie met een doorstromer is een warmwaterblokkering niet aanbevelenswaardig.



Maten (zie blz. 33)



Doorstroombiagram

(zie blz. 33)

- ① Uitlaat bad
- ② Uitlaat douche



Afmontage (zie blz. 35)



Service onderdelen (zie blz. 34)



Toebehoren (behoort niet tot het leveringspakket)

verlengset #32498000



Keurmerk (zie blz. 40)



Montage zie blz. 31



Sikkerhedsanvisninger

- △ Ved monteringen skal der bruges handsker for at undgå kvæstelser og snitsår.
- △ Større trykforskel mellem koldt og varmt vand bør udjævnes.

Monteringsanvisninger

- Før monteringen skal produktet kontrolleres for transportskader. Efter monteringen godkendes transportskader eller skader på overfladen ikke længere.
- Ledningerne og armaturerne skal monteres, skylles og kontrolleres iht. de gældende standarder.
- Installationsbestemmelserne, der gælder i det enkelte land, skal overholdes.
- Armaturet skal monteres isoleret og lydisoleret.

Montering (se s. 31)

Indbygningsdelen indbygges således, at G 3/4 tilslutningen vender nedad.

Monteringsdybde 68 mm til 96 mm.

Forlængersæt

Vær opmærksom på, at armaturet skal være slukket efter monteringen.

- A** Installation på væggen.
- B** Installation på væggen. Her med 10 mm variable monteringsskruer.
- C** Installation direkte i væggen.

Tekniske data

Driftstryk:	max. 1 MPa
Anbefalet driftstryk:	0,1 - 0,5 MPa
Prøvetryk:	1,6 MPa
(1 MPa = 10 bar = 147 PSI)	
Varmvandstemperatur:	max. 70°C
Anbefalet varmvandstemperatur:	65°C
Tilslutninger G 1/2:	Koldt højre - varmt venstre

Produktet er udelukkende beregnet til drikkevand!

Symbolbeskrivelse



Der må ikke benyttes eddikesyreholdig silikone!



Forindstilling (se s. 32)

Indstilling af varmvandsbegrænsningen. I forbindelse med gennemstrømningsvandvarmere anbefaler vi ikke en varmvandsspærre.



Målene (se s. 33)



Gennemstrømningsdiagram

(se s. 33)

- ① Afløb kar
- ② Afløb bruser



Slutmontering (se s. 35)



Reservedele (se s. 34)



Specialtilbehør (ikke med i leveringsomfang)

Forlængersæt #32498000

Godkendelse (se s. 40)



Montering se s. 31



Avisos de segurança

- ⚠ Durante a montagem devem ser utilizadas luvas de protecção, de modo a evitar ferimentos resultantes de entalamentos e de cortes.
- ⚠ Grandes diferenças entre as pressões das águas quente e fria devem ser compensadas.

Avisos de montagem

- Antes da montagem deve-se controlar o produto relativamente a danos de transporte. Após a montagem não são aceites quaisquer danos de transporte ou de superfície.
- As tubagens e a torneira têm que ser montadas, enxaguadas e verificadas de acordo com as normas em vigor.
- A prescrições de instalação válidas nos respetivos países devem ser respeitadas.
- A torneira deve ser montada de forma isolada e desacoplada sonoramente.

Montagem (ver página 31)

Montar o corpo de forma que a ligação G 3/4 se situe em baixo.

Profundidade de montagem 68 mm até 96 mm.

Crescente 28 mm

Nota: Quando terminada a instalação, certifique-se de que a misturadora se encontra fechada.

- A** Instalação sobre a parede.
- B** Instalação sobre a parede com suportes ajustáveis de 10 mm.
- C** Instalação em paredes de tijolo.

Dados Técnicos

Pressão de funcionamento:	max. 1 MPa
Pressão de func. recomendada:	0,1 - 0,5 MPa
Pressão testada:	1,6 MPa
(1 MPa = 10 bar = 147 PSI)	
Temperatura da água quente:	max. 70°C
Temp. água quente recomendada:	65°C
Ligações G 1/2:	fria à direita - quente à esquerda

Este produto foi única e exclusivamente concebido para água potável!

Descrição do símbolo



Não utilizar silicone que contenha ácido acético!



Afinação (ver página 32)

Ajuste do limitador de água quente. Em combinação com um esquentador, não é recomendável o uso de um bloqueio de água quente.



Medidas (ver página 33)



Fluxograma (ver página 33)

- ① Saída da banheira
- ② Saída do chuveiro



Acabamento Fina (ver página 35)



Peças de substituição (ver página 34)



Acessórios especiais (não incluído no volume de fornecimento)

Crescente 28 mm #32498000



Marca de controlo (ver página 40)



Montagem ver página 31



! Wskazówki bezpieczeństwa

- △ Aby uniknąć zranień na skutek zgniecenia lub przecięcia, podczas montażu należy nosić rękawice ochronne.
- △ Znaczne różnice ciśnień na doptywach ciepłej i zimnej wody muszą zostać wyrównane.

Wskazówki montażowe

- Przed montażem należy skontrolować produkt pod kątem szkód transportowych. Po montażu nie widać żadnych szkód transportowych ani szkód na powierzchni.
- Przewody i armatura muszą być montowane, płukane i kontrolowane według obowiązujących norm.
- Należy przestrzegać wytycznych instalacyjnych obowiązujących w danym kraju.
- Armaturę należy zaizolować i zamontować z izolacją dźwiękową.

Montaż (patrz strona 31)

Korpus zamontować w taki sposób, by przyłącze 3/4 było skierowane do dołu.

Głębokość montażu 68 - 96 mm

Zestaw przedłużający 28 mm

Uwaga! Mieszacz po zamontowaniu musi być zamknięty!

- A** Instalacja na ścianie.
- B** Instalacja naścienna. Tutaj ze zmiennymi rozpórkami ze śrubami gwintowanymi M 10.
- C** Instalacja w ścianie.

Dane techniczne

Ciśnienie robocze:	maks. 1 MPa
Zalecane ciśnienie robocze:	0,1 - 0,5 MPa
Ciśnienie próbne:	1,6 MPa
(1 MPa = 10 bary = 147 PSI)	
Temperatura wody gorącej:	maks. 70°C
Zalecana temperatura wody gorącej:	65°C
Przyłącza G 1/2:	Zimna z prawej - Ciepła z lewej

Produkt przeznaczony wyłącznie do wody pitnej!

Opis symbolu



Nie stosować silikonów zawierających kwas octowy!



Ustawianie (patrz strona 32)

Ustawianie ogranicznika ciepłej wody. Używanie ogranicznika temperatury wody w połączeniu z przepływowym podgrzewaczem wody nie jest zalecane.



Wymiary (patrz strona 33)



Schemat przepływu

(patrz strona 33)

- ① Odpływ wanny
- ② Odpływ prysznica



Montaż końcowy (patrz strona 35)



Części serwisowe (patrz strona 34)



Wyposażenie specjalne (Nie jest częścią dostawy)

Zestaw przedłużający 28 mm #32498000



Znak jakości (patrz strona 40)



Montaż patrz strona 31



Bezpečnostní pokyny

- ⚠ Pro zabránění řezným zraněním a pohmožděninám je nutné při montáži nosit rukavice.
- ⚠ Je nutné vyrovnat velké rozdíly tlaku mezi přípoji studené a teplé vody.

Pokyny k montáži

- Před montáží je třeba produkt zkontrolovat, zda nebyl při transportu poškozen. Po zabudování nebudou uznány žádné škody způsobené transportem nebo poškození povrchu.
- Vedení a armatura musí být namontovány, propláchnuty a otestovány podle platných norem.
- Je třeba dodržovat montážní pravidla platná v dané zemi.
- Při instalaci musí být provedena tak, aby byla baterie zaizolovaná a zvukotěsná.

Montáž (viz strana 31)

Těleso namontujte tak, aby výtok G 3/4 směřoval dolů.

Hloubka zabudování 68 mm až 96 mm.

prodloužení 28 mm

Poznámka: Po ukončení instalace zkontrolujte, jestli je baterie uzavřena!

A Instalace na stěnu.

B Instalace před stěnu. Zde s variabilními rozpěrkami pomocí šroubů M 10.

C Instalace přímo do stěny.

Technické údaje

Provozní tlak:	max. 1 MPa
Doporučený provozní tlak:	0,1 - 0,5 MPa
Zkušební tlak:	1,6 MPa
(1 MPa = 10 bar = 147 PSI)	
Teplota horké vody:	max. 70 °C
Doporučená teplota horké vody:	65 °C
Přípoje G 1/2:	studená vpravo - teplá vlevo

Výrobky Hansgrohe jsou vhodné pro přímý kontakt s pitnou vodou.

Popis symbolů



Nepoužívat silikon s obsahem kyseliny octové!



Nastavení (viz strana 32)

Nastavení omezovače teplé vody. Ve spojení s průtokovým ohřivačem se použití uzávěru teplé vody nedoporučuje.



Rozměry (viz strana 33)



Diagram průtoku

(viz strana 33)

- ① Odtok vany
- ② Odtok sprchy



Konečná montáž (viz strana 35)



Servisní díly (viz strana 34)



Zvláštní příslušenství (není součástí dodávky)

prodloužení 28 mm #32498000



Zkušební značka (viz strana 40)



Montáž viz strana 31



Bezpečnostné pokyny

- ⚠ Pri montáži musíte nosiť rukavice, aby ste predišli pomliaždeninám a rezným poraneniam.
- ⚠ Veľké rozdiely v tlaku medzi prípojkami studenej a teplej vody musia byť vyrovnané.

Pokyny pre montáž

- Pred montážou musíte produkt skontrolovať, či nebol počas transportu poškodený. Po zabudovaní nebudú uznané žiadne škody spôsobené transportom alebo poškodenia povrchu.
- Ledningarna och blandaren måste monteras, spolás igenom och kontrolleras enligt de gällande normerna.
- Je potrebné dodržiavať smernice o inštalácii, ktoré sú práve teraz platné v krajinách.
- Armatúra sa musí namontovať zaizolovaná a s oddelením od hluku v pevných telesách.

Montáž (viď strana 31)

Základné teleso namontujte tak, aby výtok G 3/4 bol dole.

Montážna hĺbka: 68 mm až 96 mm.
predĺženie 28 mm

Poznámka: Po ukončení inštalácie skontrolujte, či je batéria uzavretá!

- A** Inštalácia na stenu.
- B** Inštalácia pred stenou. Pomocou nastaviteľných skrutiek M 10.
- C** Inštalácia priamo do steny.

Technické údaje

Prevádzkový tlak:	max. 1 MPa
Doporučený prevádzkový tlak:	0,1 - 0,5 MPa
Skúšobný tlak:	1,6 MPa
(1 MPa = 10 bar = 147 PSI)	
Teplota teplej vody:	max. 70 °C
Doporučená teplota teplej vody:	65 °C
Prípoje G 1/2:	studená vpravo - teplá vľavo

Výrobok je koncipovaný výhradne pre pitnú vodu!

Popis symbolov



Nepoužívať silikón s obsahom kyseliny octovej!



Nastavenie (viď strana 32)

Nastavenie obmedzenia teplej vody. V spojení s prietokovými ohrievačmi sa neodporúča použitie obmedzovača teplej vody.



Rozmery (viď strana 33)



Diagram prietoku

(viď strana 33)

- ① Odtok vane
- ② Odtok sprchy



Konečná montáž (viď strana 35)



Servisné diely (viď strana 34)



Zvláštne príslušenstvo (nie je súčasťou dodávky)

predĺženie 28 mm #32498000



Osvedčenie o skúške (viď strana 40)



Montáž viď strana 31



安全技巧

△ 装配时为避免挤压和切割受伤，必须戴上手套。

△ 冷热水管间过大的压力差必须予以平衡。

安装提示

- 安装前必须检查产品是否受到运输损害。安装后将不认可运输损害或表面损伤。
- 管道和阀门必须根据通用标准进行安装、冲洗和检查。
- 请遵守当地国家现行的安装规定。
- 龙头必须以静噪的方式独立安装。

安装 (参见第页 31)

向下的出水口用3/4英寸管连接。

安装深度: 68mm至96 mm。

加长件28毫米

注意: 当安装完成后, 确保龙头处于关闭状态!

- A** 直接墙面安装。
- B** 直接墙面安装, 带10mm可调节的固定柱头螺栓。
- C** 砖墙安装

技术参数

工作压强: 最大 1 MPa
 推荐工作压强: 0,1 - 0,5 MPa
 测试压强: 1,6 MPa

(1 MPa = 10 bar = 147 PSI)

热水温度: 最大 70°C
 推荐热水温度: 65°C
 连接管线G 1/2: 左热右冷

该产品专为饮用水设计!

符号说明



请勿使用含有乙酸的硅胶!



调节 (参见第页 32)

热水温度调节。如果使用即热式喷头, 则不建议安装热水阀门。

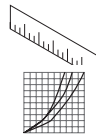

大小 (参见第页 33)

流量示意图
(参见第页 33)

- ① 浴缸出水嘴出水
- ② 淋浴出水



总装配 (参见第页 35)



备用零件 (参见第页 34)

选装附件 (不在供货范围内)



加长件28毫米 #32498000



检验标记 (参见第页 40)



安装 参见第页 31



Указания по технике безопасности

- △ Во время монтажа следует надеть перчатки во избежание прищемления и порезов.
- △ донного клапа. Перед установкой смесителя необходимо регулировочными кранами выровнять давление холодной и горячей воды при помощи вентилей регулирующих подачу воды в квартиру.

Указания по монтажу

- Перед монтажом следует проверить изделие на предмет повреждений при перевозке. После монтажа претензии о возмещении ущерба за повреждения при перевозке или повреждении поверхностей не принимаются.
- Трубы и арматура должны быть установлены, промыты и проверены в соответствии с действующими нормами.
- Необходимо соблюдать требования по монтажу, действующие в соответствующих странах.
- Арматура должна монтироваться изолированно и со звуковой защитой.

Монтаж (см. стр. 31)

Установите корпус так, чтобы выходное отверстие G 3/4 дюйма было направлено вниз.

Глубина установки от 68 до 96 мм.

Набор для удлинения 28мм

Обратите внимание на то, чтобы смеситель был закрыт после окончания монтажа!

A варианты установки

B настенный монтаж с применением фиксаторов для труб (10 мм.)

C монтаж в кирпичную стену

Технические данные

Рабочее давление: не более. 1 МПа
 Рекомендуемое рабочее давление: 0,1 - 0,5 МПа
 Давлении: 1,6 МПа
 (1 МПа = 10 bar = 147 PSI)
 Температура горячей воды: не более. 70°C
 Рекомендуемая темп. гор. воды: 65°C
 Подключение G 1/2:холодная справа - горячая слева

Изделие предназначено исключительно для питьевой воды!

Описание символов



Не применяйте силикон, содержащий уксусную кислоту.



Подгонка (см. стр. 32)

Регулировка ограничителя горячей воды. В сочетании с проточными нагревателями не рекомендуется использовать блокировку воды.

Размеры (см. стр. 33)



Схема потока

(см. стр. 33)

① Отвод ванны

② Отвод душа



Окончательная сборка (см. стр. 35)



Комплект (см. стр. 34)

Специальные принадлежности (не включено в объем поставки!)

Набор для удлинения 28мм #32498000





Знак технического контроля (см. стр. 40)



Монтаж см. стр. 31



Biztonsági utasítások

-  A szerelésnél a zúzódások és vágási sérülések elkerülése érdekében kesztyűt kell viselni.
-  A hidegvíz- és a melegvíz-csatlakozások közötti nagy nyomáskülönbséget kikell egyenlíteni!

Szerelési utasítások

- A szerelés előtt ellenőrizni kell, hogy a terméknek nincs-e szállítási sérülése. Beépítés után a szállítási- vagy felületi sérüléseket nem ismerik el.
- A vezetékeket és a csaptelepet az érvényes szabványoknak megfelelően kell felszerelni, öblíteni és ellenőrizni
- Az egyes országokban érvényes installációs irányelveket be kell tartani.
- A csaptelepet szigetelve és zajszigetelve kell felszerelni.

Szerelés (lásd a oldalon 31)

Az alaptestet úgy kell beépíteni, hogy a G 3/4 csatlakozás alul legyen.

Beépítési mélység: 68 - 96 mm

Hosszabbítókészlet: 28 mm

Ügyeljen arra, hogy a szerelés végeztével a csaptelep zárva legyen!

- A** Szerelés közvetlenül a falra.
- B** Távtartó szerkezetre való szerelés.
- C** Szerelés falba süllyesztve.

Műszaki adatok

Üzemi nyomás:	max. 1 MPa
Ajánlott üzemi nyomás:	0,1 - 0,5 MPa
Nyomáspróba:	1,6 MPa
(1 MPa = 10 bar = 147 PSI)	
Forróvíz hőmérséklet:	max. 70 °C
Forróvíz javasolt hőmérséklete:	65 °C
G 1/2 csatlakozás:	hideg jobbra - meleg balra

A terméket kizárólag ivóvízhez tervezték!

Szimbólumok leírása



Ne használjon ecetsavtartalmú szilikont!



Beállítás (lásd a oldalon 32)

A meleg víz korlátozás beállítása. Átfolyós vízmelegítőknél meleg víz korlátozó használat nem ajánlott.



Méretet (lásd a oldalon 33)



Átfolyási diagramm

(lásd a oldalon 33)

- ① Kád lefolyója
- ② Zuhany lefolyója



Beépített, kész szerelvény (lásd a oldalon 35)



Tartozékok (lásd a oldalon 34)

Egyéb tartozék (a szállítási egység nem tartalmazza)

Hosszabbítókészlet: 28 mm #32498000



Vizsgajel (lásd a oldalon 40)



Szerelés lásd a oldalon 31



Turvallisuusohjeet

- Asennuksessa on käytettävä käsineitä puristumien ja viiltojen aiheuttamien tapaturmien estämiseksi.
- Suuret paine-erot kylmä- ja kuumavesiliitäntöjen välillä on tasattava.

Asennusohjeet

- Ennen asennusta on tarkastettava tuotteen mahdolliset kuljetusvahingot. Asennuksen jälkeen kuljetus- ja pintavaurioita ei hyväksytä.
- Putket ja hana on asennettava, huuhdeltava ja tarkastettava voimassa olevien standardien mukaisesti.
- Jokaisessa maassa on noudatettava siellä päteviä asennusohjeita.
- Hana on asennettava eristettyinä ja äänenvaimennettuna.

Asennus (katso sivu 31)

Asenna perusrunko siten, että G 3/4 -liitin on alapuolella.

Asennussyvyys 68 mm - 96 mm.

Pidennyssetti 28 mm

Huomioi, että sekoittaja on suljettuna asennuksen jälkeen!

- A** Asennus seinään
- B** Asennus seinään. Tässä joustavia etäisyydenpitimiä käyttäen kaksikierteisillä 10 mm ruuveilla.
- C** Asennus suoraan seinään.

Tekniset tiedot

Käyttöpaine:	maks. 1 MPa
Suosittelut käyttöpaine:	0,1 - 0,5 MPa
Koestuspaine:	1,6 MPa
(1 MPa = 10 bar = 147 PSI)	
Kuuman veden lämpötila:	maks. 70 °C
Kuuman veden suosituslämpötila:	65 °C
Liittimet G 1/2:	kylmä oikealla - kuuma vasemmalla

Tuote on suunniteltu käytettäväksi ainoastaan juomaveden kanssa!

Merkin kuvaus



Älä käytä etikahappopitoista silikonial!



Säätö (katso sivu 32)

Lämpötilan rajoittimen säätäminen. Emme suosittele käyttämään lämpötilan rajoitinta vedenlämmittimen (läpivirtauskuumennin) yhteydessä.

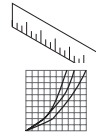

Mitat (katso sivu 33)

Virtausdiagrammi

(katso sivu 33)

- Ammeen lähtö
- Suihkun lähtö



Loppuasennus (katso sivu 35)



Varaosat (katso sivu 34)

Eriyisvaruste (ei kuulu toimitukseen)

Pidennyssetti 28 mm #32498000

Koestusmerkki (katso sivu 40)



Asennus katso sivu 31



Säkerhetsanvisningar

- △ Handskar ska bäras under monteringsarbetet så att man kan undvika kläm- och skärskadorgen werden.
- △ Stora tryckskillnader mellan anslutningarna för varmt och kallt vatten måste utjämnas.

Monteringsanvisningar

- Det måste undersökas om produkten har transportskador innan den monteras. Efter monteringen accepteras inga transport- eller ytskiktsskador.
- Ledningarna och blandaren måste monteras, spolats igenom och kontrolleras enligt de gällande normerna.
- De installationsriktlinjer som gäller i länderna ska följas.
- Blandaren måste monteras isolerat och ljudabsorberande.

Montering (se sidan 31)

Montera grundenheten så att G 3/4 anslutningen ligger nere.

Monteringsdjup 68 mm till 96 mm.

Förlängningsset 28 mm

Kontrollera att blandaren är stängd när monteringen är avslutad!

- A** Vägginstallation.
- B** Installation framför vägg. Här med variabla avståndshållare med skruvstift M 10.
- C** Installation direkt i väggen.

Tekniska data

Driftstryck:	max. 1 MPa
Rek. driftstryck:	0,1 - 0,5 MPa
Tryck vid provtryckning: (1 MPa = 10 bar = 147 PSI)	1,6 MPa
Varmvattentemperatur:	max. 70°C
Rek. varmvattentemp.:	65°C
Anslutningar G 1/2:	kallt höger - varmt vänster

Produkten är enbart avsedd för dricksvatten!

Symbolförklaring



Använd inte silikon som innehåller ättiksyra!



Justering (se sidan 32)

Ställa in varmvattenregleringen. Tillsammans med varmvattenberedare rekommenderas inte en varmvattenspär.



Måtten (se sidan 33)



Flödesschema

(se sidan 33)

- ① Avlopp kar
- ② Avlopp dusch



Slutmontering (se sidan 35)



Reservdelar (se sidan 34)



Specialtillbehör (medföljer ej leveransen)

Förlängningsset 28 mm #32498000



Testsigill (se sidan 40)



Montering se sidan 31



Saugumo technikos nurodymai

- ⚠️ Apsaugai nuo užspaudimo ir įsijovimo montavimo metu mūvėkite pirštines.
- ⚠️ Turi būti išlyginti šalto ir karšto slėgio nelygumai.

Montavimo instrukcija

- Prieš montuojant būtina patikrinti, ar gaminyje nebuvo pažeistas transportavimo metu. Sumontavus pretenzijos dėl transportavimo ir paviršiaus pažeidimų nepriimamos.
- Vamzdžiai ir sujungimai turi būti montuojami, plaunami ir tikrinami pagal galiojančias normas.
- Laikykitės atitinkamoje šalyje galiojančių direktyvų dėl įrengimo.
- Maišytuvus turi būti sumontuotas izoliuotai ir naudojant garso izoliaciją.

Montavimas (žr. psl. 31)

potinkinę dalį montuokite taip, kad G 3/4 jungtis būtų apačioje.

Montavimo gylis: nuo 68 mm iki 96 mm.

Ilginio komplektas 28 mm

Dėmesio! Po montavimo įsitikinkite, kad maišytuvus būtų uždarytas!

- A** Montavimas į sieną.
- B** Išorinis montavimas su 10 mm reguliuojamais fiksumais.
- C** Montavimas į sieną.

Techniniai duomenys

Darbinis slėgis: ne daugiau kaip 1 MPa
 Rekomenduojamas slėgis: 0,1 - 0,5 MPa
 Bandomasis slėgis: 1,6 MPa
 (1 MPa = 10 barų = 147 PSI)
 Karšto vandens temperatūra: ne daugiau kaip 70°C
 Rekomenduojama karšto vandens temperatūra: 65°C
 Prijungimas G 1/2: Šaltas vanduo dešinėje, karštas - kairėje

Produktas skirtas tik geriamajam vandeniui!

Simbolio aprašymas



Nenaudokite silikono, kurio sudėtyje yra acto rūgšties!



Reguliavimas (žr. psl. 32)

Karšto vandens ribojimas. Kartu su cirkuliaciniais šildytuvais nerekomenduojama naudoti karšto vandens blokovimo įtaisų.



Išmatavimai (žr. psl. 33)



Pralaidumo diagrama

(žr. psl. 33)

- ① Vonios išleidimas
- ② Dušo išleidimas



Galutinis montavimas (žr. psl. 35)



Atsarginės dalys (žr. psl. 34)

Specialūs priedai (nėra priedama)

Ilginio komplektas 28 mm #32498000

Bandyimo pažyma (žr. psl. 40)



Montavimas žr. psl. 31



Sigurnosne upute

- △ Prilikom montaže se radi sprječavanja prignječenja i posjekotina moraju nositi rukavice.
- △ Velika razlika u pritisku između vruće i hladne vode mora biti izbalansirana.

Upute za montažu

- Prije montaže mora se provjeriti je li proizvod oštećen prilikom transporta. Nakon ugradnje se ne priznaju nikakve reklamacije koje se odnose na površinska i transportna oštećenja.
- Cijevi i armatura moraju biti postavljeni, isprani i testirani prema važećim normama.
- Obvezno se moraju uvažiti propisi o instalacijama koji vrijede u dotičnoj zemlji.
- Montirana armatura mora biti izolirana i zvučno odvojena.

Sastavljanje (pogledaj stranicu 31)

Montirajte tijelo sa G 3/4 izlazom okrenutim prema dolje.

Dubina ugradnje 68 - 96 mm.

Set za ekstenziju 28 mm

Napomena: Po završetku instalacije provjerite da li je miješalica u položaju zatvoreno!

A Direktna instalacija u zid.

B Direktna instalacija u zid sa 10 mm podesivim vijcima.

C Instalacija u zid od cigle.

Tehnički podatci

Najveći dopušteni tlak:	tlak 1 MPa
Preporučeni tlak:	0,1 - 0,5 MPa
Probni tlak:	1,6 MPa
(1 MPa = 10 bar = 147 PSI)	
Temperatura vruće vode:	tlak 70°C
Preporučena temperatura vruće vode:	65°C
Spojevi G 1/2:	hladna desno - toplja lijevo

Proizvod je koncipiran isključivo za pitku vodu!

Opis simbola



Nemojte koristiti silikon koji sadrži octenu kiselinu!



Regulacija (pogledaj stranicu 32)

Namještanje limitera tople vode. U kombinaciji s protočnim bojlerima nije preporučljiva primjena sustava za blokiranje dotoka tople vode.



Mjere (pogledaj stranicu 33)



Dijagram protoka

(pogledaj stranicu 33)

- ① Ogranak kada
- ② Ogranak tuš



Završna montaža (pogledaj stranicu 35)



Rezervni dijelovi (pogledaj stranicu 34)

Posebni pribor (Nije sadržano u isporuci!)



Set za ekstenziju 28 mm #32498000



Oznaka testiranja (pogledaj stranicu 40)



Sastavljanje pogledaj stranicu 31



⚠ Güvenlik uyarıları

- ⚠ Montaj esnasında ezilme ve kesilme gibi yaralanmaları önlemek için eldiven kullanılmalıdır.
- ⚠ Sıcak ve soğuk su bağlantıları arasında büyük basınç farklılıkları varsa, bu basınç farklılıklarının dengelenmesi gerekir.

Montaj açıklamaları

- Montaj işleminden önce ürün nakliye hasarları yönünden kontrol edilmelidir. Montaj işleminden sonra nakliye veya yüzey hasarları için sorumluluk üstlenilmemektedir.
- Boruların ve armatürün montajı, yıkanması ve kontrolü geçerli normlara göre yapılmalıdır.
- Ülkelerde geçerli kurulum yönetmeliklerine riayet edilmelidir.
- Armatür izoleli ve ses ayırmalı olarak monte edilmektedir.

Montajı (bakınız sayfa 31)

Gövdeyi 3/4 çıkış açığı bakacak şekilde monte edin.

Montaj derinliği 68 mm ile 96 mm.

Uzatma seti 28 mm

Montaj bittikten sonra bataryanın kapalı olduğundan emin olunuz!

- A** Duvara direkt montaj
- B** 10 mm mesafe içinde duvara direkt montaj.
- C** Tuğla duvar Montajı

Teknik bilgiler

İşletme basıncı:	azami 1 MPa
Tavsiye edilen işletme basıncı:	0,1 - 0,5 MPa
Kontrol basıncı:	1,6 MPa
(1 MPa = 10 bar = 147 PSI)	
Sıcak su sıcaklığı:	azami 70°C
Tavsiye edilen su ısısı:	65°C
G 1/2 bağlantılar:	soğuk sağ - sıcak sol

Ürün sadece şebeke suyu için tasarlanmıştır!

Simge açıklaması



Asetik asit içeren silikon kullanmayın!



Ayarlama (bakınız sayfa 32)

Sıcak su sınırlamasının ayarlanması. Sıcak su kilidinin sürekli ısıtıcıyla kullanılması tavsiye edilmez.



Ölçüleri (bakınız sayfa 33)



Akış diyagramı (bakınız sayfa 33)

- ① Tekne çıkışı
- ② Su püskürtücü çıkışı



Son Uygulama (bakınız sayfa 35)



Yedek Parçalar (bakınız sayfa 34)



Özel aksesuarlar (Teslimat kapsamına dahil değildir)

Uzatma seti 28 mm #32498000



Kontrol işareti (bakınız sayfa 40)



Montajı bakınız sayfa 31



Instrucțiuni de siguranță

- △ La montare utilizați mănuși pentru evitarea contuziunilor și tăierii mâinilor.
- △ Diferențele de presiune mari între alimentarea cu apă rece și apă caldă trebuie echilibrate.

Instrucțiuni de montare

- Înainte de instalare verificați, dacă produsul prezintă deteriorări de transport. După instalare garanția nu acoperă deteriorările de transport și cele de suprafață.
- Conductele și bateriile trebuie montate, spălate și verificate conform normelor în vigoare.
- Respectați reglementările referitoare la instalare valabile în țara respectivă.
- Armătura trebuie montată cu izolație termică și fonică.

Montare (vezi pag. 31)

Montați bateria în așa fel ca racordul G 3/4 să fie pe partea inferioară.

Adâncime de montare 68 - 96 mm

Set de prelungire 28 mm

Notă: După terminarea instalării amestecătorului, asigurați-vă că acesta este închis!

A Montare pe perete.

B Montare în fața pereții. Cu distanțieri variabili și tije filetate cu diblu M 10.

C Montare direct pe perete.

Date tehnice

Presiune de funcționare:	max. 1 MPa
Presiune de funcționare recomandată:	0,1 - 0,5 MPa
Presiune de verificare:	1,6 MPa
(1 MPa = 10 bar = 147 PSI)	
Temperatura apei calde:	max. 70°C
Temperatura recomandată a apei calde:	65°C
Racorduri G 1/2 :	rece - dreapta / cald - stânga

Produsul este destinat exclusiv pentru apă potabilă.

Descrierea simbolurilor



Nu utilizați silicon cu conținut de acid acetic!



Reglare (vezi pag. 32)

Reglarea limitatorului de apă caldă. Nu se recomandă folosirea unui limitator de apă caldă în combinație cu un boiler instant.



Dimensiuni (vezi pag. 33)



Diagrama de debit

(vezi pag. 33)

- ① Orificiu de scurgere vană
- ② Orificiu de scurgere duș



Montare finală (vezi pag. 35)



Piese de schimb (vezi pag. 34)



Accesorii opționale (nu este inclus în setul livrat)

Set de prelungire 28 mm #32498000



Certificat de testare (vezi pag. 40)



Montare vezi pag. 31



⚠ Υποδείξεις ασφαλείας

- ⚠ Για να αποφύγετε τραυματισμούς κατά τη συναρμολόγηση πρέπει να φοράτε γάντια.
- ⚠ Οι διαφορές της πίεσης μεταξύ της σύνδεσης κρύου και ζεστού νερού θα πρέπει να αντισταθμίζονται.

Οδηγίες συναρμολόγησης

- Πριν τη συναρμολόγηση πρέπει να εξεταστεί το προϊόν για ζημιές μεταφοράς. Μετά την εγκατάσταση δεν αναγνωρίζονται ζημιές από τη μεταφορά ή επιφανειακές ζημιές.
- Οι σωλήνες και η μπαταρία πρέπει να τοποθετηθούν σύμφωνα με τα ισχύοντα πρότυπα, να τεθούν υπό πίεση και να δοκιμαστούν.
- Θα πρέπει να τηρούνται οι οδηγίες εγκατάστασης που ισχύουν σε κάθε κράτος.
- Η μπαταρία πρέπει να τοποθετείται με κατάλληλη διάταξη ηχομόνωσης.

Συναρμολόγηση (βλ. Σελίδα 31)

Τοποθετήστε το βασικό κορμό με την έξοδο G 3/4 προς τα κάτω.

Βάθος τοποθέτησης 68 -96 mm.

Σετ επιμήκυνσης 28 mm

Σημείωση : Όταν τελειώσει η τοποθέτηση βεβαιωθείτε ότι η μπαταρία είναι κλειστή.

A Επίτοιχη τοποθέτηση

B Εγκατάσταση "προ του τοίχου" με μεταβλητά στηρίγματα 10mm, μέσω βιδών-καρφιών M10.

C Εγκατάσταση απευθείας στον τοίχο

Τεχνικά Χαρακτηριστικά

Λειτουργία πίεσης:	έως 1 MPa
Συνιστώμενη λειτουργία πίεσης:	0,1 - 0,5 MPa
Πίεση ελέγχου:	1,6 MPa
(1 MPa = 10 bar = 147 PSI)	
Θερμοκρασία ζεστού νερού:	έως 70°C
Συνιστώμενη θερμοκρασία ζεστού νερού:	65°C
Συνδέσεις G 1/2:	κρύο δεξιά - ζεστό αριστερά

Το προϊόν έχει σχεδιαστεί αποκλειστικά για πόσιμο νερό!

Περιγραφή συμβόλων



Μην χρησιμοποιείτε σιλικόνη που περιέχει οξικό οξύ!



Ρύθμιση (βλ. Σελίδα 32)

Ρύθμιση του δοσομετρητή ζεστού νερού. Δεν συνιστάται η διάταξη φραγής ζεστού νερού σε συνδυασμό με ταχυθερμοσίφωνα.



Διαστάσεις (βλ. Σελίδα 33)



Διάγραμμα ροής
(βλ. Σελίδα 33)

- ① Εξόδος μαπανιέρας
- ② Εξόδος ντους



Τελική συναρμολόγηση (βλ. Σελίδα 35)



Ανταλλακτικά (βλ. Σελίδα 34)



Ειδικά αξεσουάρ (δεν περιλαμβάνεται στον παραδοτέο εξοπλισμό)

Σετ επιμήκυνσης 28 mm #32498000

Σήμα ελέγχου (βλ. Σελίδα 40)



Συναρμολόγηση βλ. Σελίδα 31



Varnostna opozorila

- △ Pri montaži je treba nositi rokavice, da se preprečijo poškodbe zaradi zmečkanja ali urezov.
- △ Velike razlike v tlaku med priključkom za mrzlo in priključkom za toplo vodo je potrebno izravnati.

Navodila za montažo

- Pred montažo je treba izdelek preveriti glede morebitnih transportnih poškodb. Po vgradnji transportne ali površinske poškodbe ne bodo več priznane.
- Cevi in armaturo je treba montirati, izprati in preveriti po veljavnih standardih.
- Upoštevati je treba pravilnike o inštalacijah, ki veljajo v posamezni državi.
- Armaturo morate montirati izolirano in zvočno neprepustno.

Montaža (glejte stran 31)

Vgradite osnovni del tako, da se priključek G 3/4 nahaja spodaj.

Globina vgradnje 68 do 96 mm

Podaljševalni komplet 28 mm

Pazite na to, da je mešalna baterija po končani montaži zaprta!

A Montaža na steno

B Montaža pred steno. Tukaj s prilagodljivim distančnikom in vijaki M 10.

C Montaža direktno v steno

Tehnični podatki

Delovni tlak:	maks. 1 MPa
Priporočeni delovni tlak:	0,1 - 0,5 MPa
Preskusni tlak:	1,6 MPa
(1 MPa = 10 bar = 147 PSI)	
Temperatura tople vode:	maks. 70°C
Priporočena temperatura tople vode:	65°C
Priključki G 1/2:	mrzla desno - topla levo

Proizvod je zasnovan izključno za sanitarno vodo!

Opis simbola



Ne smete uporabiti silikona, ki vsebuje očetno kislino!



Justiranje (glejte stran 32)

Nastavitev omejevalnika tople vode. V povezavi s pretočnimi grelniki uporaba zapore tople vode ni priporočljiva.



Mere (glejte stran 33)



Diagram pretoka

(glejte stran 33)

- ① Odvod banje
- ② Odvod prhe



Končna montaža (glejte stran 35)



Rezervni deli (glejte stran 34)

Poseben pribor (Ni vključeno)

Podaljševalni komplet 28 mm #32498000



Preskusni znak (glejte stran 40)



Montaža glejte stran 31



⚠ Ohutusjuhised

- ⚠ Kandke paigaldamisel muljumis- ja löikevigastuste vältimiseks kindaid.
- ⚠ Kui külma ja kuuma vee ühenduste surve on väga erinev, tuleb need tasakaalustada.

Paigaldamisjuhised

- Enne paigaldamist tuleb toodet kontrollida transpordikahjustuste osas. Pärast paigaldamist ei tunnustata enam transpordi- või pinnakahjustuste kaebuseid.
- Voolikute ja segisti paigaldamisel, loputamisel ja kontrollimisel tuleb lähtuda kehtivatest normatiividest.
- Vastavas riigis kehtivaid paigalduseeskirju tuleb järgida.
- Armatuur tuleb paigaldada isoleeritult ja helikindlalt.

Paigaldamine (vt lk 31)

Paigaldage põhikorpus nii, et G 3/4 ühendus asuks allpool.

Paigalduse sügavus 68 mm kuni 96 mm
pikenduskomplekt 28 mm

Jälgige, et segisti oleks pärast monteerimist suletud!

- A** Seinale paigaldamine.
- B** Seinale paigaldamine. Siin muudetavate vahehooldikutega, kasutades M 10 mm tikkpolte.
- C** Paigaldamine otse seinale.

Tehnilised andmed

Töörõhk	maks. 1 MPa
Soovitatav töörõhk:	0,1 - 0,5 MPa
Kontrollsurve:	1,6 MPa
(1 MPa = 10 baari = 147 PSI)	
Kuuma vee temperatuur:	maks. 70°C
Soovitatav kuuma vee temperatuur:	65°C
ühendused G 1/2:	külm paremal, kuum vasakul

Toode on ette nähtud eranditult joogivee jaoks!

Sümbolite kirjeldus



Ärge kasutage äädikhapet sisaldavat silikooni!



Reguleerimine (vt lk 32)

Sooja vee piirangu seadistamine. Ühenduses boileritega ei ole sooja vee blokeeringu soovitatav.



Mõõtude (vt lk 33)



Läbivooludiagramm

(vt lk 33)

- ① Vanni väljund
- ② Duši väljund



Löplik paigaldus (vt lk 35)



Varuosad (vt lk 34)



Spetsiaalne lisavarustus (ei sisaldu komplektis)

pikenduskomplekt 28 mm #32498000



Kontrollsertifikaat (vt lk 40)



Paigaldamine vt lk 31



Drošības norādes

- △ Montāžas laikā, lai izvairītos no saspiedumiem un iegriezumiem, nepieciešams nēsāt cimdus.
- △ Jāizlīdzina spiediena atšķirības starp aukstā un karstā ūdens pievadiem.

Norādījumi montāžai

- Pirms montāžas nepieciešams pārbaudīt, vai produktam transportēšanas laikā nav radušies bojājumi. Pēc iebūvēšanas bojājumi, kas radušies transportēšanas laikā, vai virsmas bojājumi netiek atzīti.
- Caurulvadi un armatūra ir jāuzstāda, jāizskalo un jāpārbauda saskaņā ar spēkā esošajiem standartiem.
- Jāievēro attiecīgās valstīs spēkā esošās montāžas prasības.
- Armatūra montējama izolēti un ar skaņas izolāciju.

Montāža (skat. lpp. 31)

Pamatelementu iebūvēt tā, lai G 3/4 savienojums atrastos apakšā.

Iebūvēšanas dziļums 68 mm līdz 96 mm.

Pagarināšanas komplekts 28 mm

Nemiet vērā, lai jaucējkrāns pēc montāžas būtu noslēgts!

- A** Instalācija pie sienas.
- B** Instalācija uz sienas. Šeit ar variējamām starplikām un 10 mm montāžas skrūvēm.
- C** Instalācija tieši sienā.

Tehniskie dati

Darba spiediens:	maks. 1 MPa
Ieteicamais darba spiediens:	0,1 - 0,5 MPa
Pārbaudes spiediens:	1,6 MPa
(1 MPa = 10 bar = 147 PSI)	
Karstā ūdens temperatūra:	maks. 70 °C
Ieteicamā karstā ūdens temperatūra:	65 °C
G 1/2 pieslēgumi:	aukstais pa labi - karstais pa kreisi

Izstrādājums ir paredzēts tikai dzeramajam ūdenim!

Simbolu nozīme



Neizmantojot silikonu, kas satur etiķskābi!



Ieregulēšana (skat. lpp. 32)

Karsta ūdens ierobežotāja regulēšana. Kopā ar caurteces sildītājiem nav ieteicams izmantot ūdens bloķētāju.



Izmērus (skat. lpp. 33)



Caurplūdes diagramma

(skat. lpp. 33)

- ① Vannas izeja
- ② Dušas izeja



Beigu montāža (skat. lpp. 35)



Rezerves daļas (skat. lpp. 34)



Speciāli aksesuāri (komplektā netiek piegādāts)

Pagarināšanas komplekts 28 mm #32498000



Pārbaudes zīme (skat. lpp. 40)



Montāža skat. lpp. 31



Sigurnosne napomene

- △ Prilikom montaže se radi sprečavanja prignječenja i posekotina moraju nositi rukavice.
- △ Velika razlika u pritisku između vruće i hladne vode mora biti izbalansirana.

Instrukcije za montažu

- Pre montaže se mora proveriti da li je proizvod oštećen pri transportu. Nakon ugradnje se ne priznaju nikakve reklamacije koje se odnose na površinska i transportna oštećenja.
- Vodovi i armatura moraju biti postavljeni, isprani i testirani prema važećim normama.
- Treba se pridržavati propisa koji u određenim zemljama važe za instalacije.
- Armatura se mora montirati tako da bude izolovana i zvučno odvojena.

Montaža (vidi stranu 31)

Montirajte telo s G 3/4 priključkom okrenutim prema dole.

Dubina ugradnje 68 - 96 mm.

Produžna garnitura 28 mm

Obratite pažnju da kada se završi montaža mešač mora biti zatvoren!

- A** Direktna instalacija na zid.
- B** Instalacija ispred zida s varijabilnim držačem odstojanja pomoću 10 mm zavrtnja.
- C** Instalacija direktno u zid.

Tehnički podaci

Radni pritisak:	maks. 1 MPa
Preporučeni radni pritisak:	0,1 - 0,5 MPa
Probni pritisak:	1,6 MPa
(1 MPa = 10 bar = 147 PSI)	
Temperatura vruće vode:	maks. 70°C
Preporučena temperatura vruće vode:	65°C
Priključci G 1/2:	hladna voda desno - topla levo

Proizvod je koncipiran isključivo za pijaću vodu!

Opis simbola



Nemojte koristiti silikon koji sadrži sirćetnu kiselinu!



Podešavanje (vidi stranu 32)

Podešavanje ograničivača tople vode. U kombinaciji sa protočnim bojlerima ne preporučuje se primena sistema za blokiranje dotoka tople vode.



Mere (vidi stranu 33)



Dijagram protoka

(vidi stranu 33)

- ① Ogranak kada
- ② Ogranak tuš



Završna montaža (vidi stranu 35)



Rezervni delovi (vidi stranu 34)

Poseban pribor (Nije sadržano u isporuci)

Produžna garnitura 28 mm #32498000

Ispitni znak (vidi stranu 40)



Montaža vidi stranu 31



Sikkerhetshenvisninger

- △ Bruk hansker under montasjen for å unngå klem- og kuttskader.
- △ Store trykkdifferanser mellom kaldt- og varmtvannstilkoblinger skal utlignes.

Montagehenvisninger

- Før montasjen skal produktet sjekkes for transportskader. Etter monteringen aksepteres ikke noen transport- eller overflateskader.
- Ledningene og armaturen skal monteres, spyles og sjekkes iht. de gyldige normer.
- Gjeldende retningslinjer for rørleggerarbeid i de enkelte land skal følges.
- Armaturen skal monteres isolert og støyfrikoblet.

Montasje (se side 31)

Basiselementet bygges inn slik at G 3/4 tilkoblingen er nede.

Innbyggingsdybde 68 mm til 96 mm.

Forlengelses-sett 28 mm

Påse at blanderen er lukket etter fullført montasje

- A** Installasjon på vegg
- B** Installasjon foran veggen. Her med variable avstandsholdere via spesialskruer M 10.
- C** Installasjon rett på vegg.

Tekniske data

Driftstrykk	maks. 1 MPa
Anbefalt driftstrykk:	0,1 - 0,5 MPa
Prøvetrykk	1,6 MPa
(1 MPa = 10 bar = 147 PSI)	
Varmtvannstemperatur	maks. 70°C
Anbefalt temperatur for varmt vann	65°C
Tilkoblinger G 1/2	kaldt høyre - varm venstre

Produktet er utelukkende designet for drikkevann!

Symbolbeskrivelse



Ikke bruk silikon som inneholder eddiksyre!



Justering (se side 32)

Innstilling av varmtvannsbegrensning. I forbindelse med gjennomstrømningsvarmere er det ikke anbefalt å bruke en varmtvannssperre.

Mål (se side 33)



Gjennomstrømningsdiagram

(se side 33)

- ① Utgang kar
- ② Utgang dusj



Sluttmontasje (se side 35)



Serviceleder (se side 34)

Ekstratilbehør (ikke med i leveransen)

Forlengelses-sett 28 mm #32498000



Prøvemerket (se side 40)



Montasje se side 31



Указания за безопасност

- ⚠ При монтажа трябва да се носят ръкавици, за да се избегнат наранявания поради притискане или порязване.
- ⚠ Големите разлики в налягането между изводите за студената и топлата вода трябва да се изравняват.

Указания за монтаж

- Преди монтажа продуктът трябва да се провери за транспортни щети. След монтажа не се признават транспортни или повърхностни щети.
- Тръбопроводите и арматурата трябва да се монтират, промият и проверят в съответствие с валидните норми.
- Трябва да бъдат спазвани валидните в съответните страни предписания за инсталиране.
- Арматурата трябва да се монтира изолирана и не свързана с шум.

Монтаж (вижте стр. 31)

Монтирайте основното тяло така, че изводът G 3/4 да се намира отдолу.

Монтажна дълбочина 68 мм до 96 мм.

Удължителен комплект 28 мм

Обърнете внимание на това, след монтажа смесителят да бъде затворен!

A Инсталация на стената.

B Инсталация пред стената. Тук с регулиращи се разпънки с помощта на комбинирани болтове M 10.

C Инсталация директно в стената.

Технически данни

Работно налягане:	макс. 1 МПа
Препоръчително работно налягане:	0,1 - 0,5 МПа
Контролно налягане:	1,6 МПа
(1 МПа = 10 bar = 147 PSI)	
Температура на горещата вода:	макс. 70°C
Препоръчителна температура на горещата вода:	65°C
Изводи G 1/2:	студено отлясно – топло отляво

Продуктът е разработен само за питейна вода!

Описание на символите



Не използвайте силикон, съдържащ оцетна киселина!



Юстиране (вижте стр. 32)

Настройка на ограничителя за топлата вода. Във връзка с проточни нагреватели не се препоръчва блокировка за топлата вода



Размери (вижте стр. 33)



Диаграма на потока

(вижте стр. 33)

- ① Извод вана
- ② Изход разпръсквател



Довършителен монтаж (вижте стр. 35)



Сервизни части (вижте стр. 34)



Специални принадлежности

(не се съдържа в обема на доставка)

Удължителен комплект 28 мм #32498000



Контролен знак (вижте стр. 40)



Монтаж вижте стр. 31



Udhëzime sigurie

- △ Për të evituar lëndimet e pickimeve ose të prerjeve gjatë procesit të montimit duhet që të vishni doreza.
- △ Ndryshimet e mëdha të presionit mes lidhjeve të ujit të ftohtë dhe atij të ngrohtë duhen ekuilibruar.

Udhëzime për montimin

- Përpara montimit duhet që produkti të kontrollohet për dëmtime nga transporti. Pas instalimit nuk do të njihet asnjë dëmtim nga transporti ose dëmtim i sipërfaqes.
- Tubacionet dhe rubinetet duhet që të montohen, të shpëlahen dhe të kontrollohen sipas standardeve në fuqi
- Duhet të respektohen linjat udhëzuese të instalimit, të vlefshme për vendet respektive.
- Valvula duhet të izolohet dhe të izoluar akustikisht montuar.

Montimi (shih faqen 31)

Trupi themelor duhet montuar në atë mënyrë që lidhja G 3/4 të ndodhet poshtë.

Thellësia e montimit 68 mm deri 96 mm.

Kompleti zgjatës 28 mm.

Vini re që rubineti me ujë të përzier të jetë i mbyllur pas përfundimit të montimit!

- A** Instalimi në mur.
- B** Instalimi para murit. Këtu me distancues të paqëndrueshëm përmes vidhave lidhëse M 10.
- C** Instalimi direkt në mur.

Të dhëna teknike

Presioni gjatë punës	maks. 1 MPa
Presioni i rekomanduar:	0,1 - 0,5 MPa
Presioni për provë:	1,6 MPa
(1 MPa = 10 bar = 147 PSI)	
Temperatura e ujit të ngrohtë	maks. 70°C
Temperatura e rekomanduar e ujit të ngrohtë:	65°C
Lidhjet G 1/2:	i ftohtë djathtas - i ngrohtë majtas

Produkti është projektuar ekskluzivisht për ujë të pijshëm!

Përshkrimi i simbolit



Mos përdorni silikon që në përbërje ka acid acetik.



Justimi (shih faqen 32)

Rregullimi i kufizimit me ujë të nxehtë. Një kombinim me një bojler ujit nuk është i rekomanduar.

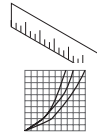

Përmasat (shih faqen 33)

Diagrami i qarkullimit

(shih faqen 33)

- ① Dalja e vaskës
- ② Dalja e spërkatëses



Montimi përfundimtar (shih faqen 35)



Pjesët e servisit (shih faqen 34)

Pajisje të posaçme (nuk përfshihet në vëllimin e furnizimit)

Kompleti zgjatës 28 mm. #32498000

Shenja e kontrollit (shih faqen 40)



Montimi shih faqen 31



المواصفات الفنية

ضغط التشغيل: الحد الأقصى 1 ميجاباسكال
 ضغط التشغيل الموصى به: 0,1 - 0,5 ميجاباسكال
 ضغط الاختبار: 1,6 ميجاباسكال
 (1 ميجاباسكال = 10 بار = 147 PSI)
 درجة حرارة الماء الساخن: الحد الأقصى 70°C
 درجة الحرارة الموصى بها للماء الساخن: 65°C
 الوصلات G 1/2: الماء البارد جهة اليمين - الماء الساخن جهة اليسار
 المنتج مخصص فقط لماء الشرب!

⚠ تنبيهات الأمان

⚠ يجب إرتداء قفازات لليد أثناء التركيب لتجنب حدوث أخطار الإنحشار أو الجروح.
 ⚠ يجب أن يكون تيار الماء الساخن والماء البارد متعادلين في الضغط.

تعليمات التركيب

- قبل القيام بعملية التركيب، يجب فحص المنتج للتأكد من خلوه من أية تلفيات ناتجة عن النقل. بعد القيام بعملية التركيب، لن يتم الاعتراف بوجود أية تلفيات سطحية أو تلفيات ناتجة عن عملية النقل.
 - يجب تركيب وغسيل واختبار التوصيلات وخلطات المياه طبقاً للمعايير السارية.
 - يجب مراعاة القواعد الخاصة بالتركيب وأعمال السباكة وفقاً للوائح الخاصة بكل بلد.
 - يجب تركيب خلط المياه بعد عزله وفصله عن الاحتكاكات بمواد البناء داخل المكان الذي يركب به.
- التركيب (راجع صفحة 31)**

قم بتركيب الجسم بمخرج G ثلاثة أرباع بوصة متجهاً لأسفل.

عمق التركيب: من 68 مم حتى 96 مم.
 طقم إطالة 28 مم

ملاحظة: عند الانتهاء من التركيب تأكد من إغلاق الخلاط!

وصف الرمز

هام! لا تستخدم السليكون الذي يحتوي على أحماض!



الضبط (راجع صفحة 32)



ضبط تحديد المياه الدافئة. لا ينصح باستخدام محدد المياه الدافئة مع سخان المياه الوتقي.

أبعاد (راجع صفحة 33)



رسم للصرف (راجع صفحة 33)



- ① صرف البانيو
- ② صرف الرشاش

التجميع النهائي (راجع صفحة 35)



قطع الغيار (راجع صفحة 34)



ملحقات خاصة (غير مدرج مع المحتويات المسلمة)

طقم إطالة 28 مم #32498000



شهادة اختبار (راجع صفحة 40)



التركيب راجع صفحة 31



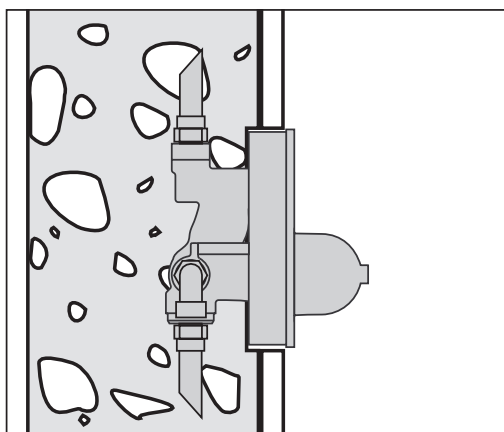
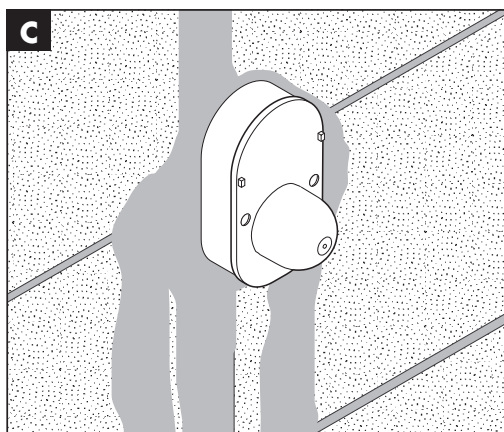
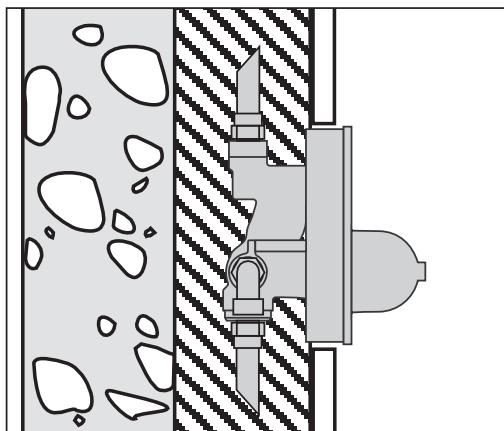
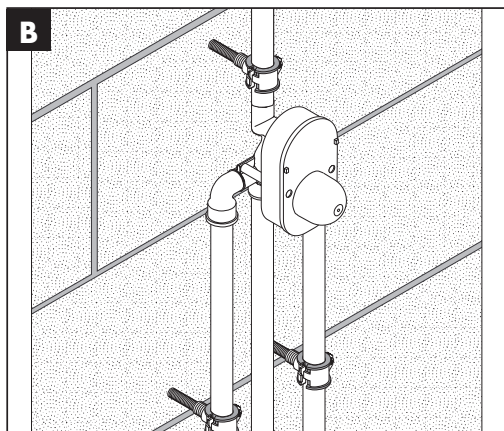
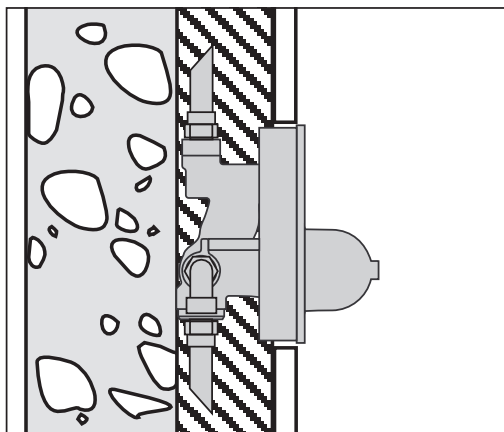
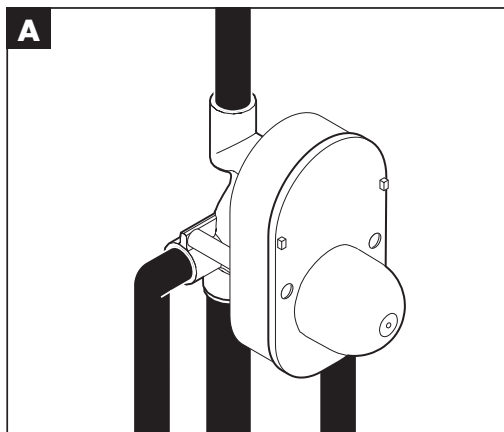



60 °C



10 °C



0,3 MPa
0,3 МПа
0,3 میجاباسکال

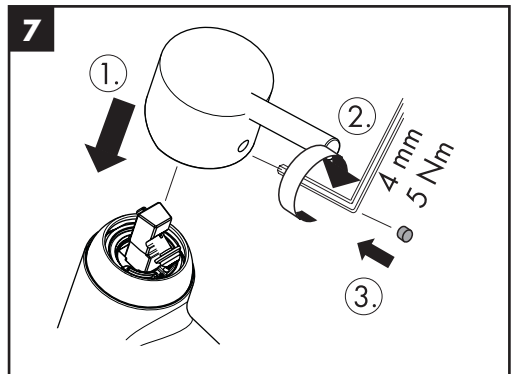
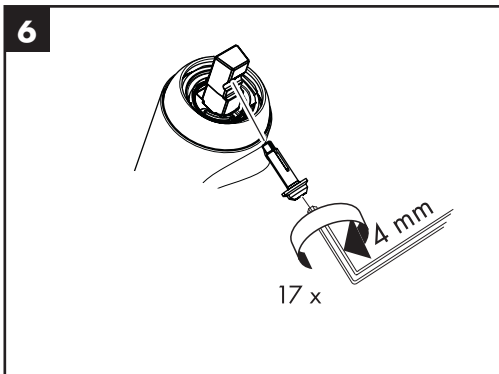
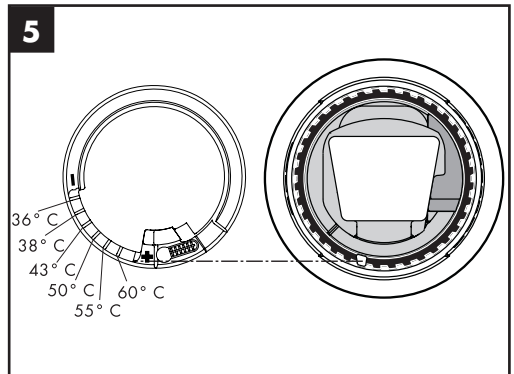
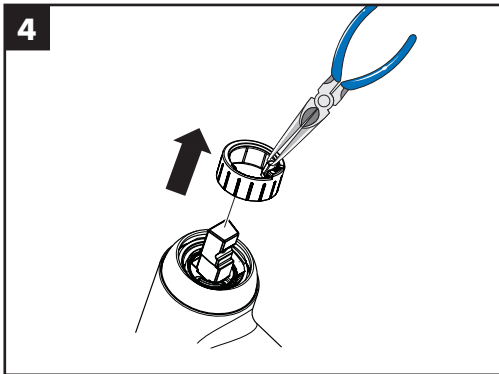
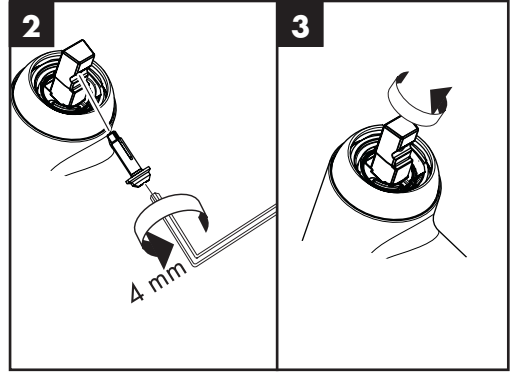
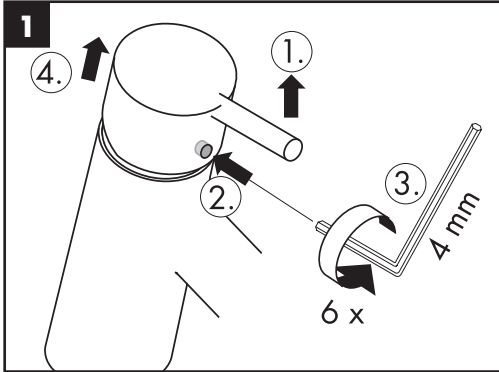

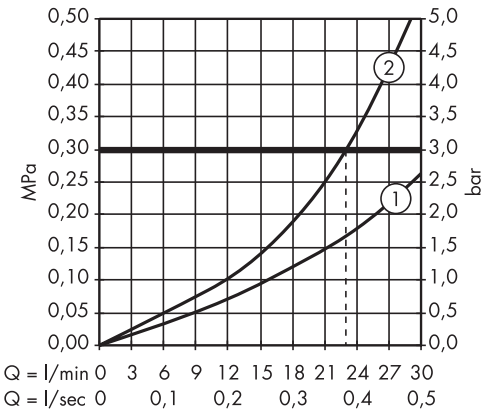
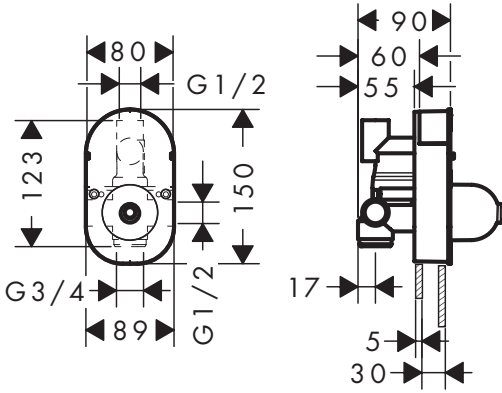
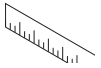

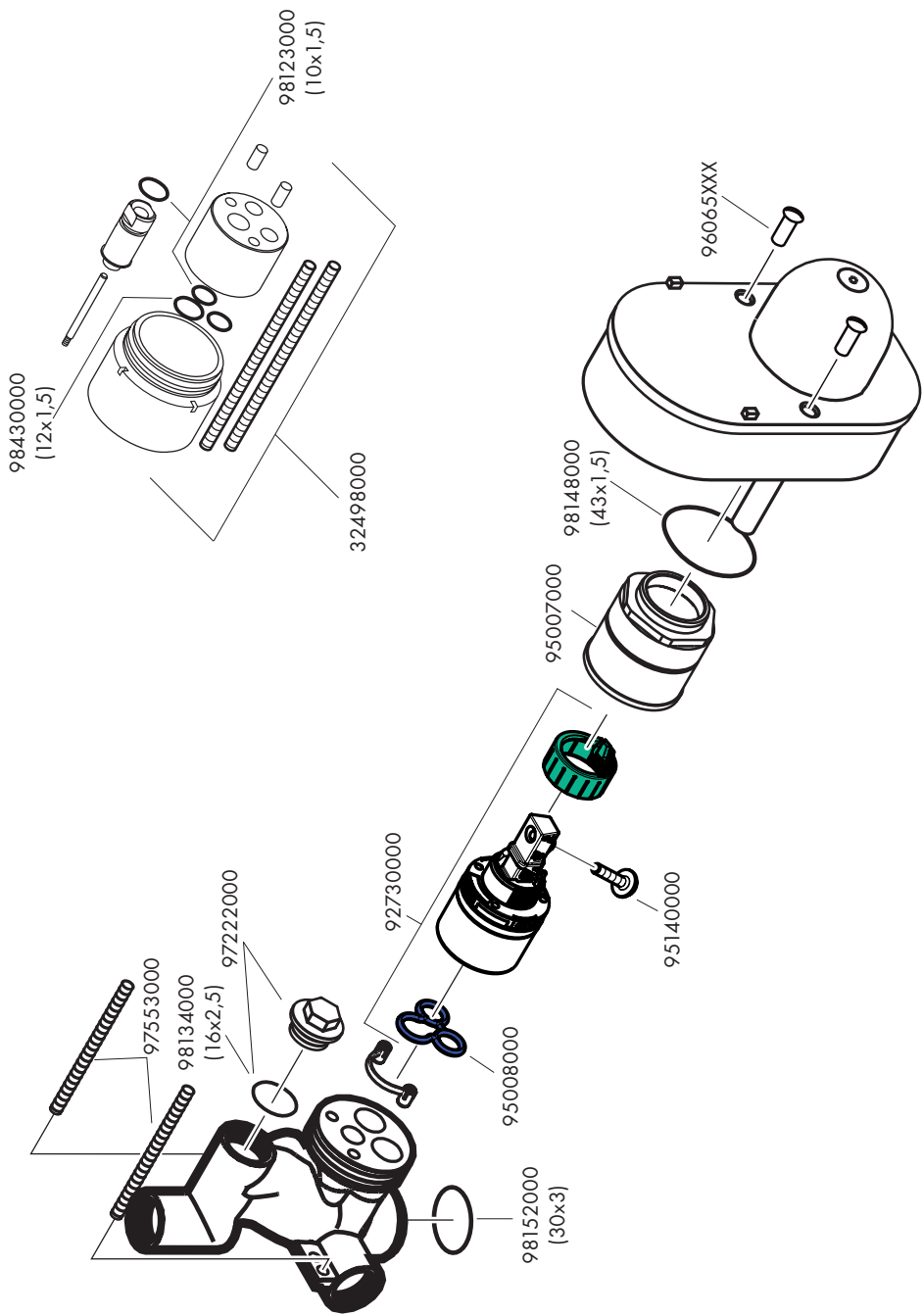



Metris
31484000

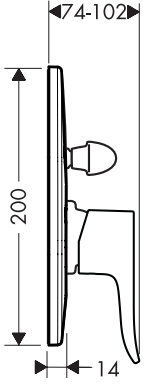

Talis E²
31635000

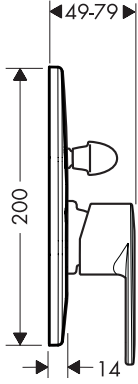

31947000 /
31688000

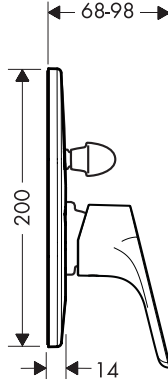

Logis
71406000 / 71409000

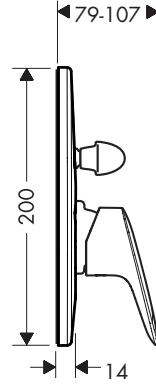

Talis E
71746000

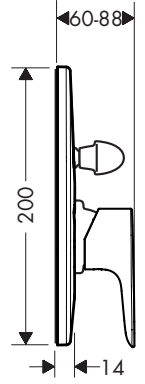

Talis S
72407000

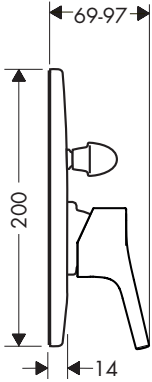

Status²
14185000

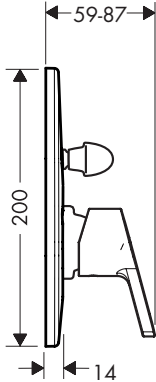

Avista
31759000

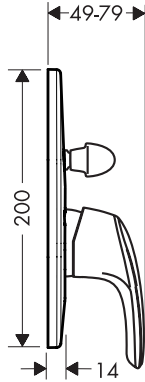

Sportive2
31775000

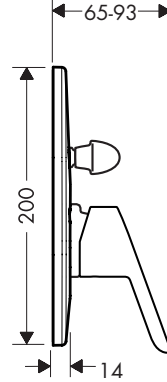

Ecos
31779000

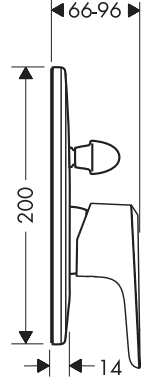

MyCube
71245000

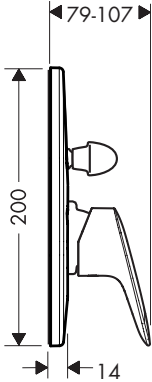

MySport
71246000

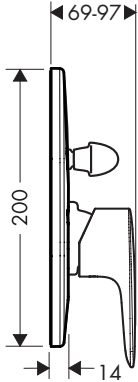

Decor
31947223

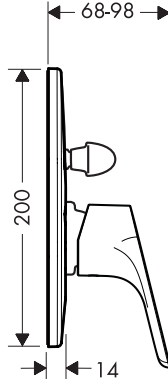

Novus
71047000

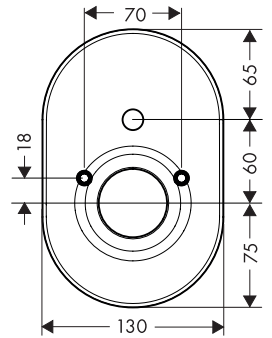
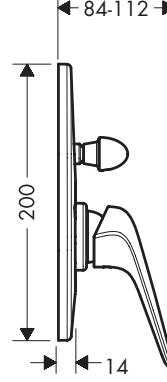







	P-IX	DVGW	SVGW	NF	WRAS	KIWA	ACS	ETA
31741180					X		X	
