

Plan Care

34981010037 Складное сиденье

ИЗДЕЛИЕ



ЧЕРТЕЖ

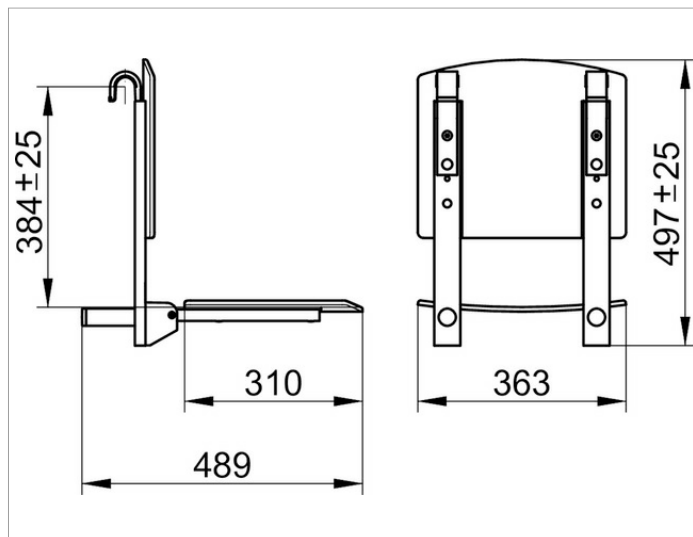

ОПИСАНИЕ ИЗДЕЛИЯ

для навешивания на поручни,
а также поручни вдоль стены и штангу для душа,
сиденье откидывается вверх

поверхность

хром/темно-серый (RAL 7021)

спецификации

KEUCO PLAN CARE Tip-up seat 34981010037
tip-up seat in chrome-plated/dark-grey (RAL 7021)
made from polypropylene
in esthetic, practical design, for rail system
safe seating arrangement in the shower
anti-static, easy to clean
plastic brackets for mounting onto support grip/ hand bar and plastic
buffer onto wall tiles
to tilt upwards, seat can carry weight up to 110 kg
width 362 mm, length of area 310mm

For completion necessary:
Articles from the Plan Care rail system
(Art. no. 34901 – 34915)